

MAIOR P 300.1 PR
MAIOR P 400.1 PR



Technical data



Operating instructions



Electric diagrams



Spare parts list

MAIOR P 300.1 PR TC 230-400-50	3121045
MAIOR P 300.1 PR TL 230-400-50	3121046
MAIOR P 300.1 PR TC 230-400-50 NS	3143734
MAIOR P 300.1 PR TL 230-400-50 NS	3143735
MAIOR P 400.1 PR TC 230-400-50	3121047
MAIOR P 400.1 PR TL 230-400-50	3121048
MAIOR P 400.1 PR TC 230-400-50 NS	3143736
MAIOR P 400.1 PR TL 230-400-50 NS	3143737



420010466601

INDEX

MAIOR P 300.1

MAIOR P 400.1



General warnings - Conformity declaration	3
Burner designation - Modular delivery system	4
Burner description	5
Electrical control panel	5
Technical data	6
Working diagrams	7
Test boiler - Flame dimension	7
Overall dimensions	8
Oil operating mode - General safety functions	9
Installation	10
Fitting the burner to the boiler	10
Oil connection	11
Feeding and suction line for light oil	12
Electrical connections	13
Start-up: Checking procedure, Recording commissioning data	14
Exhaust gas test	15
Start-up oil side	16
Fuel selection - Start-up	16
Adjusting the max air flow rate	16
Firing head setting	16
Adjusting the max oil flow rate	17
Servomotor SQM50 - Air damper motor pre-setting	17
Adjusting the pump pressure	17
Adjusting the intermediate burner capacity	18
Servomotor SQM50 - Oil side final setting	18
Maintenance program	19
Troubleshooting instructions	20
Operating troubles	21
Appendix	22
Control box - Damper actuators	23
Fluidics nozzle chart	24
Bergonzo nozzle tables	25
Pump and pressure regulators	27
Electrical diagrams	28
Spare parts list	30

GENERAL WARNINGS - CONFORMITY DECLARATION

Important notes

Ecoflam burners have been designed and built in compliance with all current regulations and directives.



All burners comply to the safety and energy saving operation regulations within the standard of their respective performance range.



The burner must not operate outside the working range.

The quality is guaranteed by a quality and management system certified in accordance with ISO 9001:2008.

MAIOR PR burners are designed for the low-pollutant combustion of light oil.



The burners comply with standard EN267. Assembly and commissioning must be carried out only by authorised specialists and all applicable guidelines and directives must be observed.

Burner description

MAIOR PR burners are progressive mechanical fully automatic monoblock devices. Burner head is designed to get the lowest emissions in terms of NOx and unburnt particles in order to maximize the heat generator efficiency. Emissions can be different respect to the ones recorded in the lab because they depends a lot on the generator on which the burner is fit.

The installer must comply with compulsory rules. Avoid for instance dangerous atmosphere or not ventilated rooms.

Packaging and handling

Move the burner still in its packaging using a trolley or forklift, taking care not to drop it and elevating it no more than 20cm from ground level. After having removed the packaging, check that the contents are in good condition and correspond with what was ordered. If in doubt, contact the manufacturer.



The burner must be installed by a qualified individual.

If the weight and dimensions do not allow for manual lifting, ask another operator for help or use a forklift, harness the burner

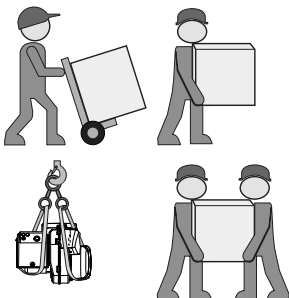

using belts if no eyebolts are available.



Use the accessories provided (flange, gasket, pins and nuts) to install the burner onto the boiler, taking care not to damage the isolating gasket.

We can accept no warranty liability whatsoever for loss, damage or injury caused by any of the following:

- Inappropriate use.
- Incorrect assembly or repair by the customer or any third party, including the fitting of non-original parts.
- non authorised modifications made on the burner.

Provision of the system and the operating instructions

The firing system manufacturer must supply the operator of the system with operating and maintenance instructions on or before final delivery. These instructions should be displayed in a prominent location at the point of installation of the heat generator, and should include the address and telephone number of the nearest customer service centre.

Notes for the operator

The system should be inspected by a specialist at least once a year. It is advisable to take out a maintenance contract to guarantee regular servicing.

Installation location

The burner must not be operated in rooms containing aggressive vapours (e.g. spray, perchloroethylene, hydrocarbon tetrachloride, solvent, etc.) or tending to heavy dust formation or high air humidity. Adequate ventilation must be provided at the place of installation of the furnace system to ensure a reliable supply with combustion air.

Declaration of conformity for oil fuel burners

We,

Ecoflam Bruciatori S.p.A.

declare under our sole responsibility that the oil fuel burners named

MAIOR

conform to the following standards:

EN 267	EN 50156-1
EN 55014-1	EN 55014-2
EN 60335-1	EN 60335-2-102
EN 61000-6-2	EN 61000-6-3

These products bear the CE mark in accordance with the stipulations of the following directives:

**2014/35/UE Low Voltage Directive
2014/30/UE EMC Directive
2006/42/EC Machine directive
2011/65/EU RoHS2 directive
(EU) 2016/426 Gas Appliance Regulation.**

April, 2018 / Mr. Filippo Maltempo

R&D Director



BURNER SELECTION: Type of operation and configuration must be done by professional personnel in order to grant correct working of the burner. Installation, start-up and maintenance must be carried out by authorised specialists and all applicable guidelines and regulations (including local safety regulations and codes of practise) must be observed.

BURNER DESIGNATION

MAIOR P 300.1 PR TC 230-400-50

RANGE NAME BY FUEL TYPE

MAIOR Light oil

MODEL SIZE (Gas: kW; Oil: kg/h)

MAIOR P 300.1 253 kg/h - 3000 kW

EMISSIONS

- Standard Class 1 - OIL EN267 (<250 mg/kWh)

OPERATION TYPE

PR 2 stages progressive mechanical gas / oil

MD 2 stages modulating mechanical with PID

E 2 stages modulating electronic

HEAD TYPE

TC Short head

TL Long head

FUEL

Light oil

BIODIESEL Biodiesel

KEROSENE Kerosene

ELECTRICAL POWER SUPPLY

230-400V/50Hz 230-400 Volt, 50 Hz

MODULAR DELIVERY SYSTEM

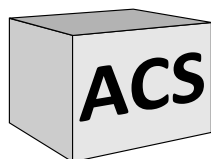
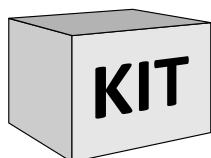
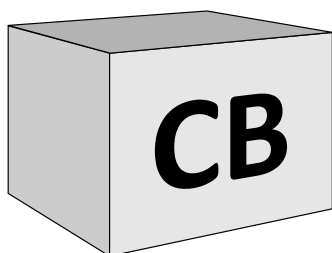

Light oil burners

All light oil burners are delivered complete in one single packaging including filter and flexible hoses up to 6 MW.

Additional accessories and options shall be installed by the installer in accordance to the instruction and local safety regulations and codes of practise.

KITS - Accessories

Kits and accessories are managed and delivered separately.

Component type

CB	Complete burner
KIT	Kits
ACS	Accessories

BURNER DESCRIPTION

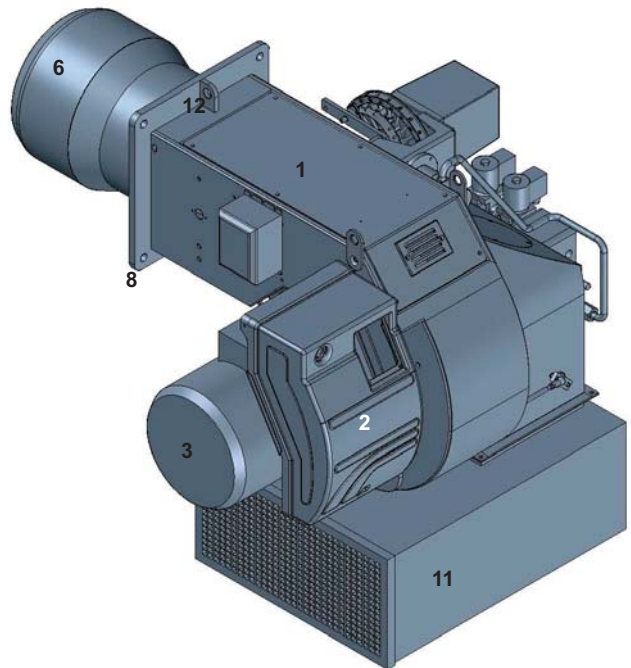
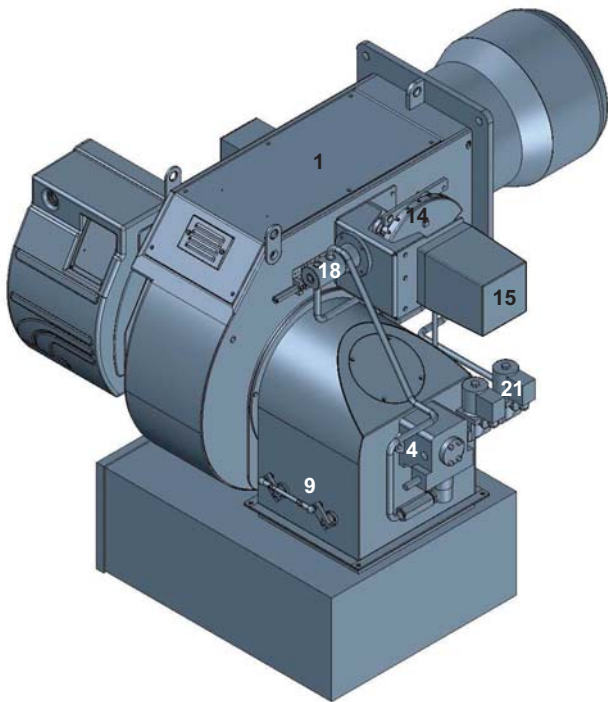

LEGENDA

- | | |
|-----------------------------|----------------------------|
| 1. Housing | 12. Lifting eyebolts |
| 2. Electrical control panel | 14. Mechanical cam oil |
| 3. Blower motor | 15. Servomotor |
| 4. Pump | 18. Oil pressure regulator |
| 6. Blast tube | 21. Oil coil |
| 8. Burner fixing flange | |
| 9. Air flap regulation | |
| 11. Silencer | |

Control panel

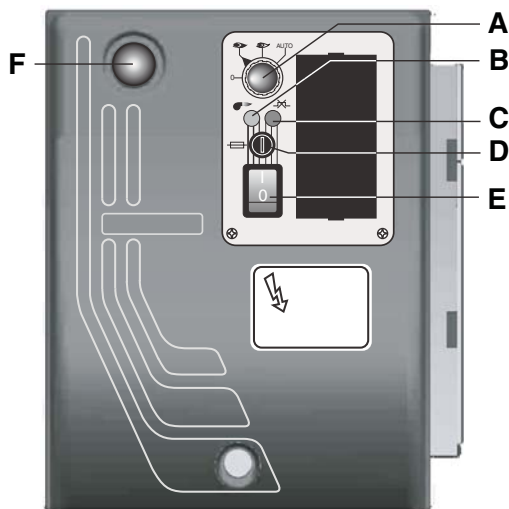

- A - selector :
 - 0 = operating elements locked in an intermediate position
 - 1 = operation on maximum capacity
 - 2 = operation on minimum capacity
 - 3 = automatic operation
- B - working lamp
- C - thermal lock-out lamp
- D - fuse
- E - main switch I / O
- F - reset key

TECHNICAL DATA

MODEL		MAIOR P 300.1	MAIOR P 400.1
Thermal power max.	kW	3.000	3.900
	kcal/h	2.586.000	3.365.000
	kg/h	250	330
Thermal power min.	kW	1000	1300
	kcal/h	860.000	1.122.000
	kg/h	85	110
Operation mode	Type	Progressive mechanical oil - Modulating with PID	
Regulation ratio nominal	Type	1+3 OIL	
Fuel	Type	Light oil (L.C.V. 10.200 kcal/kg max. visc 1,6+6 mm ² /s at 20°C) (EL) Hu = 11,86 kWh/kg	
Emission class	std	Standard Class 1 OIL EN267 (<250 mg/kWh)	
Control unit	Type	SIEMENS LAL	
Air regulation	Type	Air flap	Air flap
Air flap control with servomotor	Model	SQM50	
Flame monitoring	Type	photoresistor	
Ignitier	Model	BRAHMA	
Motor	kW	7,5	9
Rpm	N°	2.800	2.800
Voltage	V/Hz	230/400 V - 50 Hz	
Total power consumption operation	W	9.000	11.000
Weight body BBCH	Kg		
Electrical panel protection level	IP	IP40	IP40
Sound pressure level without silencer	dB(A) Lab tests	87,3	88,3
Sound pressure level with silencer		81,8	83
Ambient temperature storage	Min/Max	-20°...+70° C	
Ambient temperature use		-10°...+60° C	
Oil pump	Model	TA3	TA3
Nozzles	Type	according to the output requested	

WORKING DIAGRAMS

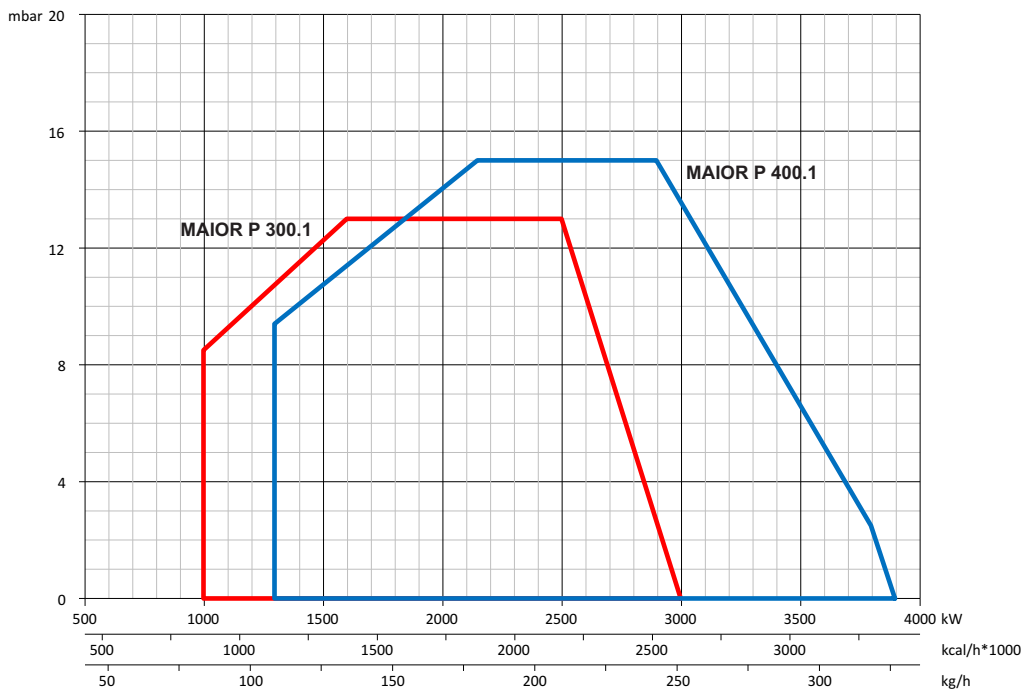

Calculation of burner output
 Q_F = Burner output (kW)
 Q_N = Rated boiler output (kW)
 η = Boiler efficiency (%)

$$Q_F = \frac{Q_N}{\eta} \times 100$$

Working fields

The working field shows burner output as a function of combustion chamber pressure. It corresponds to the maximum values specified by EN267 measured at the test fire tube. Boiler efficiency should be taken into consideration when selecting the burner.

TEST BOILER - FLAME DIMENSIONS

FLAME LENGTH LIGHT OIL BURNERS

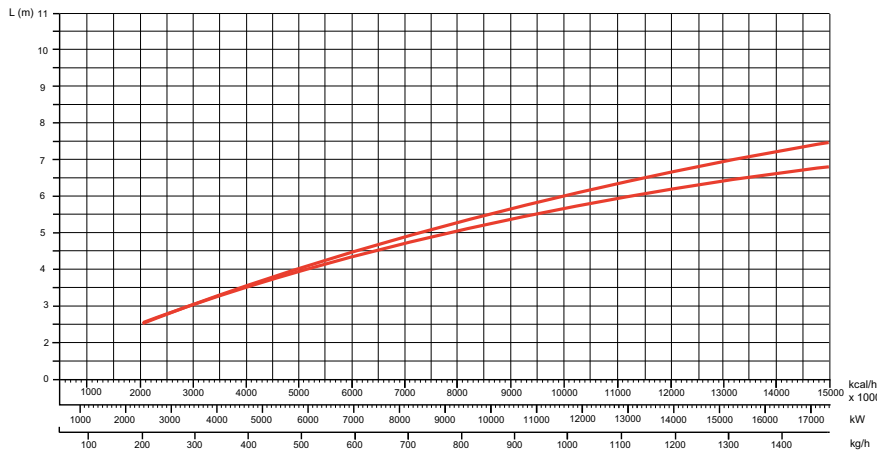

FLAME DIAMETER LIGHT OIL BURNERS

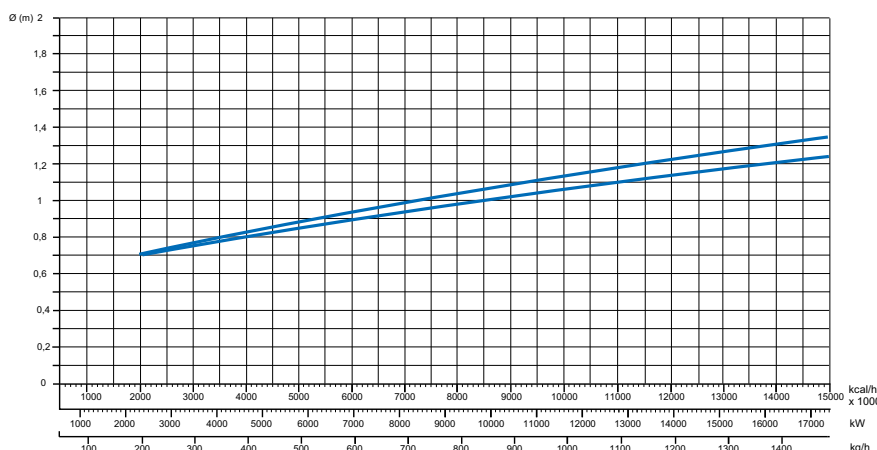

The burner/boiler matching does not pose any problem if the boiler is CE type-approved.

If the burner must be combined with a boiler that has not been CE type-approved and/or its combustion chamber dimensions are clearly smaller than those indicated in diagram, consult the manufacturer.

The firing rates were set in relation to special test boilers, according to EN267 regulations.

The sizes are indicative and depend on the configuration, to the combustion chamber pressure and to the draught. The values have been taken out from tests executed with flame tubes.

The dimensions of the flame are made in test boiler in laboratory without resistance therefore exists max and min length that take into account the difference in length that comes from the boiler backpressure.

Example:

Burner thermal output = 8000 kW;

L flame (m) = 5 m (medium value)

D flame (m) = 1 m (medium value)

WARNING: Some flame modifications can be done in our FLEXSHOP in the factory in order to shape the flame and adapt it to some special boiler or application.

OVERALL DIMENSIONS

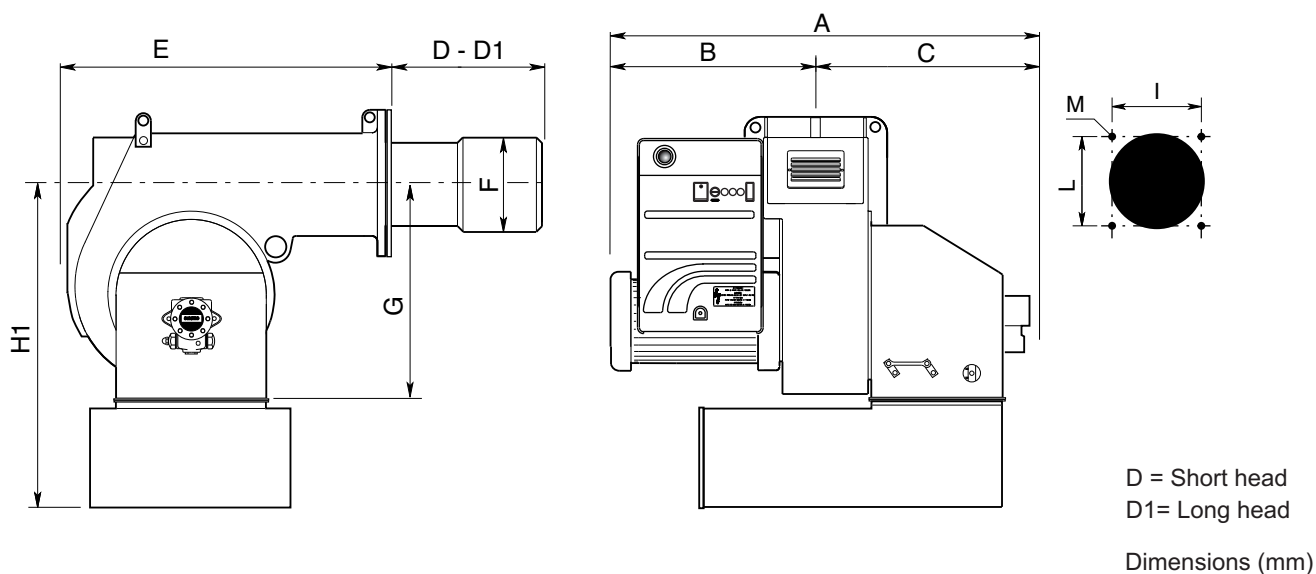

Model	A	B	C	D	D1	E	F	G	H1	I	L	M
MAIOR P 300.1	1055	502	553	330	530	810	290	471	746	315	315	M16
MAIOR P 400.1	1100	547	553	345	545	810	320	471	746	315	315	M16

Burner-boiler mounting flange

Fixing hole dimensions are "I" and "L" as per dimension table.
Boiler hole shall be done according to the blast tube dimension "F" plus 15-25 mm in order to be able to extract it during maintenance.

WARNING: Please follow the suggested dimension for the hole on the boiler flange in order to fit the burner. Make sure that between the boiler and the blast tube proper insulation is fitted.

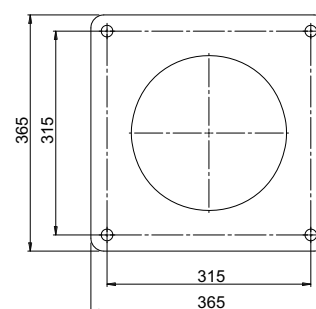

Packaging (only burner)

Model	X	Y	Z	kg
MAIOR P 300.1 PR TC	1140	1370	940	
MAIOR P 300.1 PR TL	1140	1620	940	
MAIOR P 400.1 PR TC	1140	1370	940	
MAIOR P 400.1 PR TL	1140	1620	940	

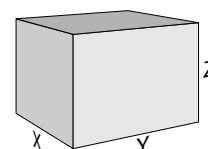

OIL OPERATING MODE - GENERAL SAFETY FUNCTIONS

START-UP MODE

As soon as the furnace system is required to supply heat the burner control circuit will close and the program be started. After the program has run down the burner will start. The air damper is closed when the burner is out of operation.

The automatic furnace controller controls and monitors the starting function.

The electric actuator opens the closed air damper to its full-load position so that the burner will sweep the furnace compartment and exhaust ports at the required air flow rates. At the end of the specified pre-ventilation time the air damper will be moved into its partial load position. This operation will be followed by the pre-ignition procedure and the oil feed start.

The solenoid valves will open and thus allow the pressurized oil to flow to the nozzle and to the return line.

The oil will be atomized, mixed with the combustion air and ignited.

A safety period is provided to allow the flame to develop a proper and steady pattern.

On the termination of the safety period, a flame signal must have been received by the automatic furnace controller via the flame monitor and remain on until the

regular shut-off.

The startup program of the burner has now been completed.

OIL OPERATING MODE

After the flame has developed the load regulator will be enabled which brings the burner into its operating position.

The load regulator will now control the burner automatically between its partial-load and full-load stages.

Depending on the heat demand, the electric actuator of the mechanical compound control system will be fed with the OPEN or CLOSE signal via the regulator and thus increase or decrease the oil and air flow rates.

This compound control system will vary the positions of the oil control valve and air damper and thus regulate the oil flow rate in conjunction with the air flow rate. The burner can either be controlled in two-stage sliding mode or, if a respective controller is provided, in stepless control mode.

The stepless control will allow the burner to be operated at any desired stage between its partial-load and full-load

positions. The burner will be turned off from its partial-load position. The air damper will be closed when the burner is out of operation and will thus prevent cold air flowing through the burner chamber, heat exchanger and chimney.

The interior cooling losses will be greatly minimized.

Oil control:

2-stage sliding

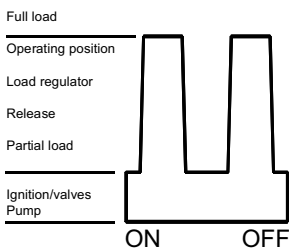

Stepless

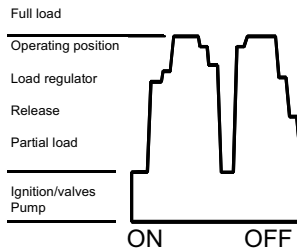

GENERAL SAFETY FUNCTIONS

In case a flame does not develop when starting the burner (fuel release) the burner will shut off at the end of the safety period (safety lock-out).

A safety lock-out will also occur in the case of flame failure during operation, air flow failure during the pre-ventilation phase and pressure failure during the whole period of burner operation.

Any failure of the flame signal at the end of the safety period and a flame signal during

the pre-ventilation phase (external light control) will result in a safety lock-out with the control box being locked.

The trouble is indicated by the trouble signal lamp lighting up.

The control box can be unlocked immediately after a safety lock-out by pressing the unlocking key. The program unit will return to its starting position and proceed with the restart of the burner.

A voltage failure will result in a regular shut-off of the burner. Upon voltage

recovery there may be an automatic restart unless another interlock is provided, e.g. by the safety system. In any case of trouble the fuel oil supply will be shut off right away. The program unit will stop at the same time causing also the trouble location indicator to stop.

The symbols will indicate the kind of trouble.

INSTALLATION

Fitting the burner to the boiler



WARNING: handling and moving operations must be carried out by specialised personnel. Use the eyebolts to lift the burner in order that it will not overturn and fall down.

To perform the installation of the burner into the boiler drill the boiler plate according to the dimension given on this manual and place the burner towards it by lifting and moving the burner by means of eyebolts.

Place the gasket on the burner flange and install the burner into the boiler by fixing nuts into the bolts. The space between the blast tube and the boiler lining must be sealed with appropriate insulating material.

Burner blast tube insertion depth and brickwork

Unless otherwise specified by the boiler manufacturer, heat generators without a cooled front wall require brickwork or insulation 5 as shown in the illustration. The brickwork must not protrude beyond the leading edge of the blast tube, and should have a minimum conical angle of 60° . Gap 6 must be filled with an elastic, non-combustible insulation material. For boilers with reverse firing, the minimum burner tube insertion depth A as specified in the boiler manufacturer's instructions must be observed.

On boilers the blast tube insertion depth should be observed as per the boiler manufacturer's instructions.

Reverse flame boiler :

A = 50-100 mm.

Three pass boilers :

A1 = 50-100 mm.

Exhaust system

To avoid unfavourable noise emissions, right-angled connectors should not be used on the flue gas side of the boiler.

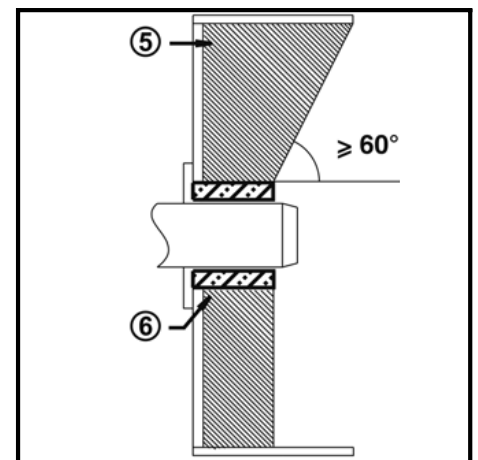
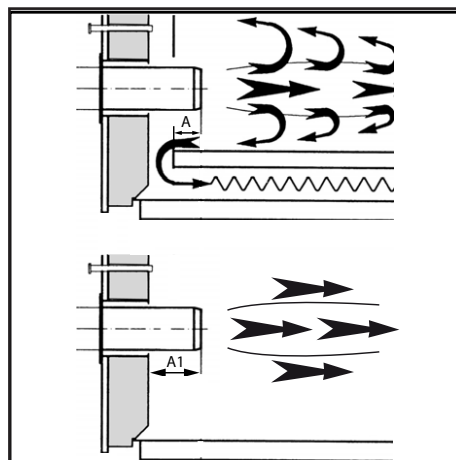
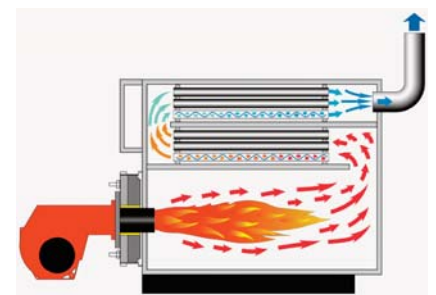
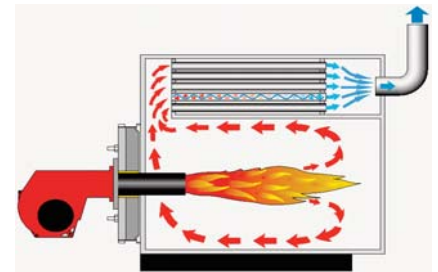
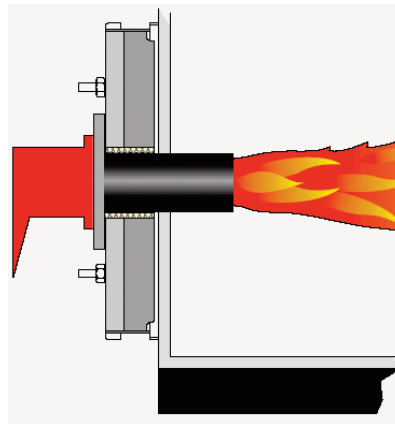

BURNER LINING

Check before burner installation:

1. Depending on the type of boiler (reverse flame or three pass) check the burner blast tube installation depth according to the data specified by the boiler manufacturer or consult the burner producer.

2. Check the ignition electrodes on the burner head as per factory setting (see figures). The setting of the mixing and ignition unit according to the boiler output will be performed during commissioning procedure.

3. Check that the head is preset at 50%.

Position of the electrodes - nozzle installation

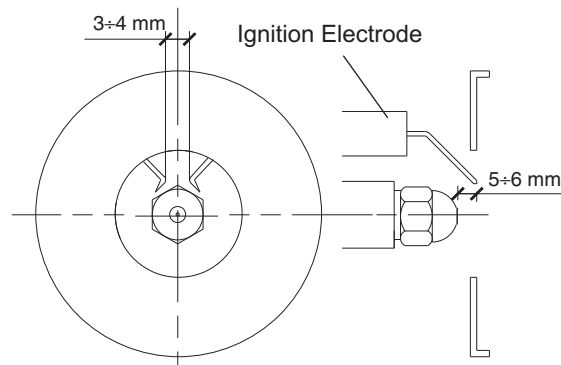

MAIN SWITCH

0 - OFF

1 - ON



INSTALLATION

Oil connection

! **WARNING:** make sure that the feeding line is properly dimensioned and is in compliance with the local safety rules and code of practise in the country of installation

HYDRAULIC CIRCUIT LIGHT OIL FEEDING

- 176: oil pump
- 178: solenoid valve
- 184: output control valve
- 311: return oil pressure switch
- CV: check valve
- RL: return line
- VL: suction line
- VLO: working oil valve

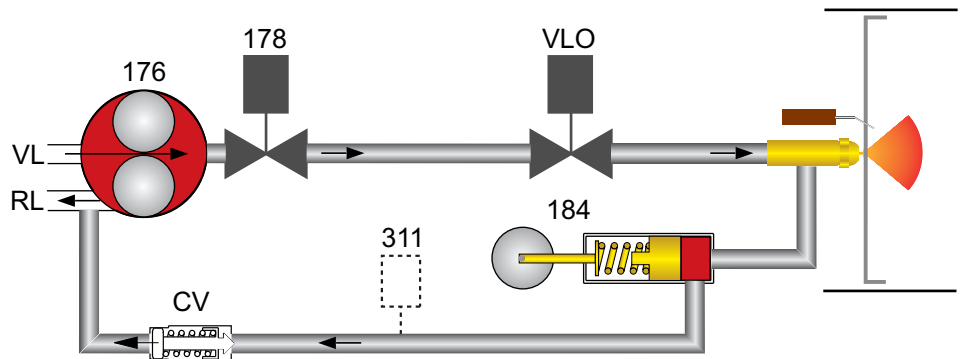

OIL PRESSURE CONTROL (FEED)

The feed pressure is controlled by means of the pressure regulator installed in the pump and should be set at 25 bar. The pressure regulator is operated by turning its screw. Make sure to fill the pump with oil prior to taking into operation.

PUMP BLEEDING

Open the feed and return stop valves and ensure the ring line (if any) is in operation. Reduce the oil pressure at the pressure regulating valve. Turn on the pump by pressing the contactor. Check the pump for proper direction of rotation. Check for proper oil delivery and absence of leaks in the hydraulic oil system. For bleeding the pump open the pressure gauge connection, for example. When taking the burner into operation pro

ceed by gradually increasing the pressure to operating level (25 bar).

CHECKING THE PRESSURE (OIL SUCTION PRESSURE)

The maximum permissible vacuum is 0,4 bar. At higher vacuum levels the fuel oil will tend to separate air from oil which may lead to operating trouble. In the ring line mode of operation the recommended oil pressure is 2 bar.

OIL CONNECTION

Hoses are used for connection to the oil lines and stop valves. The hoses must be installed according to the applicable standards (relieved of tensile load, free of distortion) to avoid kinking and exclude the danger of breakage. Take care when mounting the oil lines to bring their ends as

close to the burners as possible and to arrange them in a way that the boiler door and the burner can be swing out without any obstruction.

Refer to the technical documentation for the line dimensions for the feed and return lines from the stop valves to the tank.

OIL FILTER

A filter must be installed upstream of the pump to protect the oil pressure pump and the hydraulic system.

INSTALLATION OPTIONS

- Two-line installation (separate feed and return lines without delivery pump).
- Ring line system (with delivery pump and gas-air separator).

LEGENDA

1. Inlet
2. Return
3. Bleed and pressure gauge port
4. Vacuum gauge port
5. Pressure adjustment
6. Nozzle outlet
7. Heater
8. Hose
9. Oil filter
10. Oil ball valve

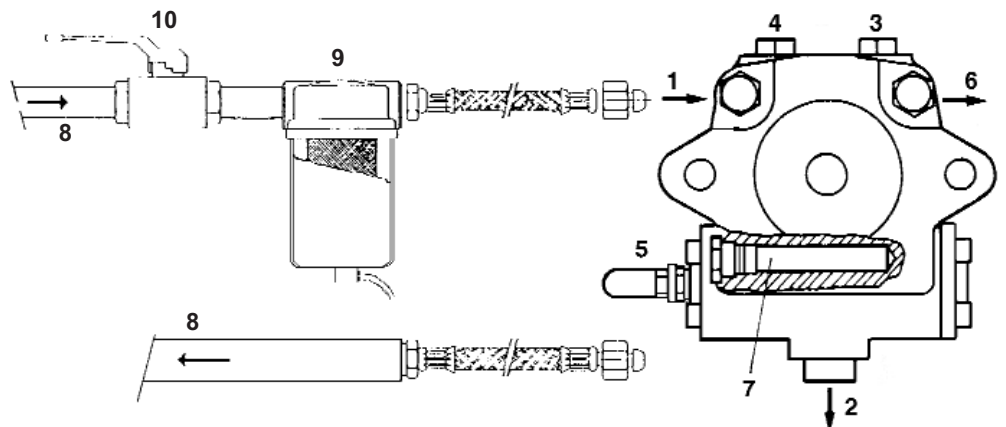

! **WARNING:** Check that the pump rotation is correct and before start up it has been pre-filled

INSTALLATION

Feeding and suction line for light oil

SUCTION LINE LENGTHS FOR PIPE SYSTEMS

- Two-pipe siphon feed system

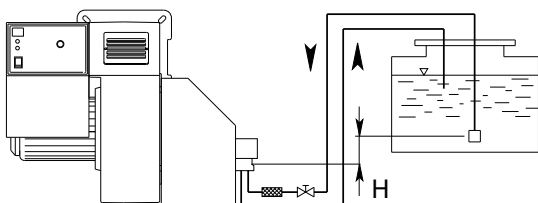

- Two-pipe lift system

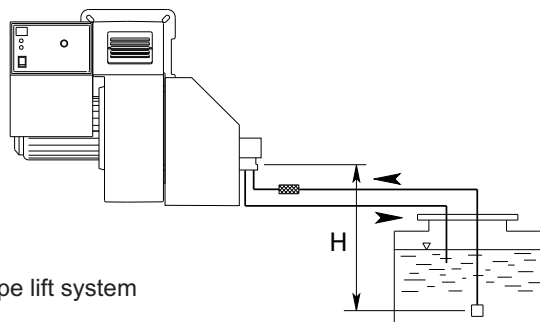

The burner is equipped with a self-priming pump which is capable of feeding itself within the limits listed in the table at the side.

H (m)	PIPE LENGTH (m)		
	TA3		
	ø 14 mm	ø 16 mm	ø 20 mm
3	10	32	115
2,5	8	28	110
2	7	25	100
1,5	6	22	95
1	5	20	85
0,5	--	17	75
0	--	15	65
-0,5	--	10	55
-1	--	5	45
-1,5	--	--	37
-2	--	--	30
-2,5	--	--	22
-3	--	--	9
-3,5	--	--	--
-4	--	--	--

WARNING: To calculate the length of the pipework all the straight parts, curves, up and down pipes must be taken into consideration. The static suction height is the distance between the standing valve and the axis of the burner pump.

Negative pressure must not exceed 0,45 bar; if negative pressure is greater pump operation may become faulty, leading to an increase in mechanical noise and perhaps even breakage.

All oil ring installations must comply with the local safety rules existing in the country of installation

The pumps that are used can be installed both into single-pipe and double-pipe systems:

Single-pipe system: a single pipe drives the oil from the tank to the pump's inlet that deliver the pressurized oil to the nozzle and part of the oil not used goes back to the pump. With this single pipe the by-pass plug must be removed and the return port must be sealed with steel plug and washer.

Double-pipe system: this is the default solution from the factory. The return pipe send the excess oil from the pump to the tank. Depending on the type of pump used to change from a 1-pipe system to a 2-pipe-system, insert the by-pass plug (as for ccw-rotation referring to the pump shaft).

Note for commissioning: during commissioning, the filter, pipelines and pumps must be pre-filled with fuel oil and vented. The direction of rotation of the motor should be checked. When commissioning it must be ensured that pump never run dry.

NOZZLE SELECTION

Please refer to diagram to select Ecoflam recommended nozzle for the output that is required given the output necessary in the installation. Regular maintenance is highly recommended.

Nozzle has to be cleaned in petrol and if filter or other parts are defective or damaged the nozzle must be replaced.

NOZZLE CHART IS AVAILABLE ON APPENDIX PAGE

SUNTEC TA

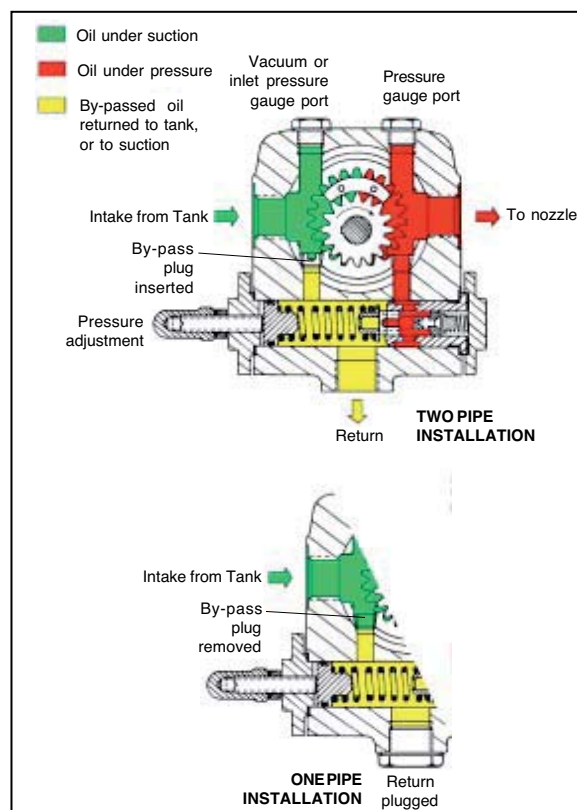

INSTALLATION

Electrical connections

! **WARNING:** Electrical wiring must be carried out with electrical supply disconnected and with burner switch in position OFF. Electrical supply must correspond to the one shown on the burner label.

APPLICABLE STANDARD

The electrical connection work comprising all the installation materials, terminals and earth connections must be carried out in accordance with the applicable regulations. For the electrical installation of the burner care must be taken to observe the circuit diagram made out for the furnace system.

The electrical connection of the burner and instruments shall be entrusted to authorized specialists only.

NOTE: For the installation of the connection cables care must be taken to provide cable loops of sufficient length to allow for the swing-out of the boiler door and burner.

Make sure after the completion of the electrical connection work to check the wiring of the electrical system of the burner. This should include a check of the direction of rotation of the burner motor (fan).

GENERAL WARNINGS:

All applicable electrical safety regulations must be followed. Failure to correctly dimension the suitable input power and earth the equipment may cause damages to person and compromise the correct function of the burner therefore the electrical system shall be checked by qualified personnel.

The manufacturer declines all responsibility for modifications or connections different from those shown in the electrical scheme.

Adapters, multiple plugs and extension cables may not be used for the equipment's power supply.

An omnipolar switch in accordance with current safety regulations is required for the mains supply connection.

ELECTRICAL CONNECTION

1) of the burner

- Built-in electrical cabinet

Use cable gland in order to secure the required level of protection. All the links, power and control, are connected to the terminal block of the cabinet. Provide cables in sufficient length to secure the rotation of the burner body according to the assembly.

Check and adjust the size of the contactors and thermal relays and the wires section according to the motor and supply voltage specs.

ATTENTION: Wiring is not supplied.

The burners are produced with connections suitable for power supply 380-400 V three-phase.

The burners with electric motors of an output lower or equal to 3 kW can be adapted to 220-230 V (please follow the instructions on the backside); motors with higher output can only work 380-400 V three-phase.

In case of request of burners different from the above mentioned standard, it is recommended to make specific mention in the order.

Instructions: how to adapt electric motors of an output lower or equal to 3 kW to 220-230 V power supply

It is possible to change the voltage of the burner by operating as follows:

1. change the connection inside the electric box of the motor, from star to delta (see picture 1);
2. change the setting of the thermal relay, referring to the absorption values indicated in the motor nameplate. If necessary, replace the thermal relay with another one of suitable scale. This operation is not possible on motors above 3 kW.

For more information, please contact the Ecoflam staff.

PROBES CONNECTION ACTIVE PROBE CONNECTION (FOR MODULATING VERSION)

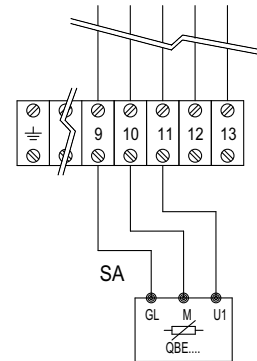

PASSIVE PROBE CONNECTION (FOR MODULATING VERSION)

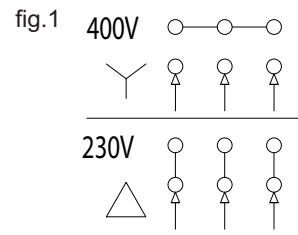
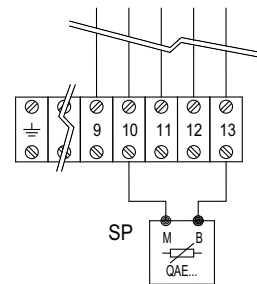

LEGENDA

- HLB: lock-out lamp
- STAB: two stages thermostat
- HLF: burner on flame lamp
- STC: boiler thermostat
- STS: safety thermostat
- SA: active probe
- SP: passive probe

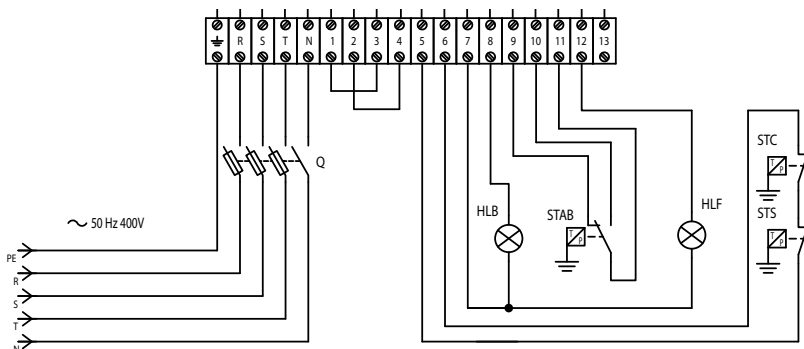

START-UP: CHECKING PROCEDURE, RECORDING COMMISSIONING DATA

CHECKS BEFORE COMMISSIONING:

- That the burner is assembled in accordance with the instructions given here.
- Setting the combustion components.
- All electrical connections must be correct.
- Check the burner motor for correct direction of rotation.
- The heat generator must be ready for operation, and the operating regulations for the heat generator must be observed.
- The heat generator and heating system must be filled with water and the circulating pumps must be in operation.
- The temperature regulator, pressure regulator, low water detectors and any other safety or limiting devices that might be fitted must be connected and operational.
- The exhaust gas duct must be unobstructed and the secondary air system, if available, must be operational.
- An adequate supply of fresh air must be guaranteed.
- Check tank, lines and oil pump are filled with oil and correct oil nozzle is fitted.
- With burner in starting position check that air damper is in "CLOSED" position.
- Check that control box is unlocked and in its original position.
- A standard-compliant measuring point must be available, the exhaust gas duct up to the measuring point must be free of leaks to prevent anomalies in the measurement results.

OIL START-UP

Open all shut-off valves of oil supply system.

- Set fuel selector switch to its "Oil" position.
- Fill pump with oil.
- Mount pressure gauge in the feed line and return line.
- Mount the pressure gauge for checking the pump suction pressure.
- Make sure that the nozzle is size and mounted correctly.

Bleeding of oil system

Shortly start the burner and check for proper direction of rotation. Bleed the oil line and oil pump.

CAUTION: The hydraulic system has been filled with oil by the manufacturer. This may cause ignition trouble when initially operating the system. When starting the burner take care to increase the oil pressure slowly to the operating level.

Prior to the initial fuel feed start make a functional test of the burner program flow:

Oil system:

- Open all shut-off valves of the oil supply system.
- The oil solenoid valve in the feed line disconnect on the terminal strip (see Circuit Diagram).
- Start burner and check program flow for correct start-up sequence:
 1. Fan starts.
 2. Pre-ventilating damper.
 3. Air pressure check.
 4. Partial-load air damper.
 5. Ignition.
 6. Valves open (disconnected valve remains closed).
 7. Safety lock-out after expiry of safety period (see control box).
- Reconnect the valve.
- Unlock the control box.



Recording commissioning data

Test	n°1	n°2	n°3	n°4
Date				
Model				
Type oil				
Oil calorific value				
Burner output	min	kW		
Burner output	max	kW		
Flue gas temperature		C°		
Air temperature		C°		
CO ₂		%		
CO		ppm		
NOx		ppm		
Performance		%		
Corrective action				
Operator name				
Company				

EXHAUST GAS TEST

To ensure an economically efficient and trouble-free operation of the system it will be necessary to adjust the burner specifically in accordance with the furnace system. This is achieved by means of a fuel-combustion air compound control unit which adjusts the burner to ensure a proper combustion. Exhaust gas tests are required for this purpose.

The percentage CO₂ and O₂ and the exhaust gas temperature will have to be measured to determine the efficiency and combustion quality.

Prior to any measurement make sure to check the boiler and exhaust gas system for absence of leaks.

Secondary air will falsify the measured results

Check that the exhaust gases have a residual oxygen (O₂) content as low as possible and a carbon dioxide (CO₂) content as high as possible.

The carbon monoxide content of the exhaust gases must be below the currently applicable specifications in all load stages.

In the fuel oil combustion mode the permissible soot number in the exhaust gas is not allowed to be exceeded.

Recommended combustion parameters

Fuel	Recommended (%) CO ₂	Recommended (%) O ₂
Natural gas	10 ÷ 9	3,1 ÷ 4,8
Light oil	13 ÷ 11,5	3,3 ÷ 5,3
Heavy oil	12,5 ÷ 11	4,2 ÷ 6,2

WARNING: if the installation is above sea level the output of the burner vary base on the diagram.

The regulation of the burner in this case shall take into account the reduced power of the burner due to the missing air.

Ratio between O₂- and CO₂- for natural gas H (CO₂max = 11,7%)

Ratio between O₂- and CO₂- for light oil EL (CO₂max = 15,40%)

Ratio between O₂- and CO₂- for heavy oil S (CO₂max = 15,60%)

$$O_2 = 21 \frac{CO_2max - CO_2gem}{CO_2max} = \%$$

CO₂ gem = % CO₂ measured on dry flue gases

Mean air pressure vs. altitude above sea-level

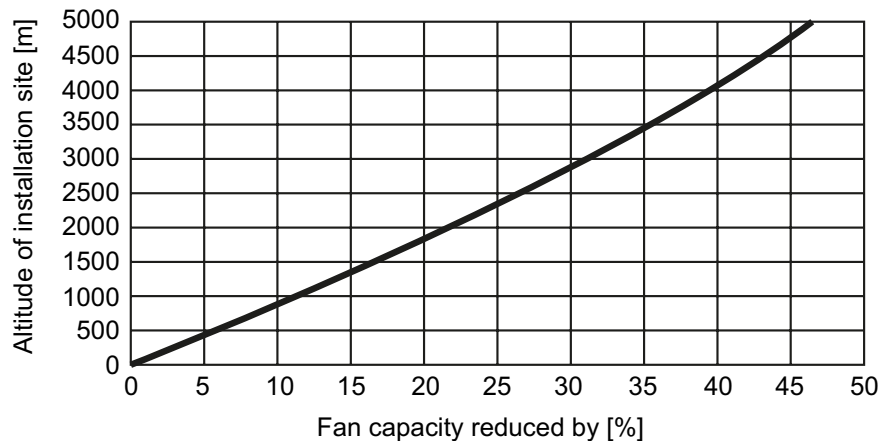

START-UP OIL SIDE

Fuel selection - Start-up

Select the oil operation in order to proceed with start up on the oil side. On the selector put the operation on minimum capacity.

MAIN SWITCH

0 - OFF

1 - ON

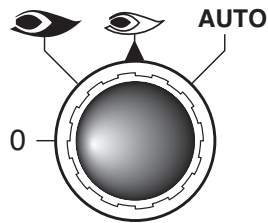

0 : operating elements locked in an intermediate position

 : operation on maximum capacity

 : operation on minimum capacity

AUTO : automatic operation



KMV



KMV contactor: check the air fan motor rotation.
If the rotation is not correct invert the two phases on the power supply.

START UP THE BURNER

The control box starts the pre-purge cycle, the fan motor and the oil motor and opens the air flaps in full open position.

At the end of pre-purging, the control box drives the servomotor into the ignition position and starts the ignition transformer.

After a few seconds the control box opens the oil valve and starts the flame. After the flame stabilisation the control box drives the servomotor in the low flame.

In case of faulty ignition, the control box switches the burner into safety condition, in such a case you must rearm the burner.

Gradually go step by step using the selector on position 0 to stop the flame, from the low flame to the high flame in order to have a stable flame. For each position from 0 to 90° do oil setting adjusting oil return pressure as described in the next pages. When the servomotor arrives at 90° you have completed first tuning of air and oil flow according to the boiler capacity required. Check the combustion values and adjust the oil pressure.

Adjusting the maximum air flow rate

In order to adjust the maximum air flow rate see figure with selector in maximum operation. Loosen the nut holding the air damper transmission rod and correct air flow till you reach the combustion values suggested by reading the value on the combustion analyser. If you do not reach acceptable air flow rate you shall adjust the firing head. Move the head forward to increase air flow backwards to reduce.

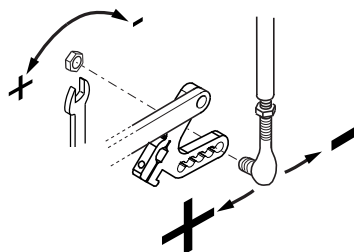

Firing head setting

The firing head is pre-adjusted at the 50% from the factory. The setting fully open enables to reach the full power of the burner and full close to reach the minimum power of the burner. The optimal position depends on the output that we need to reach but the default setting shall be modified only when you are not able to reach the suggested combustion value by adjusting the air flow in the maximum flame.

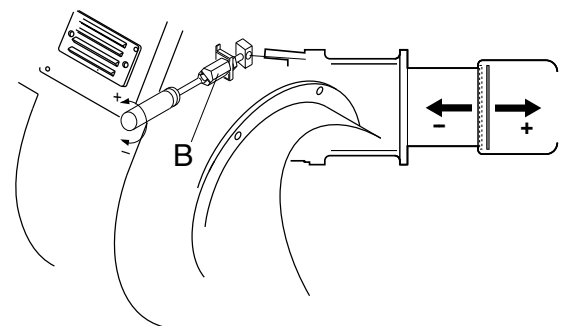

START-UP OIL SIDE

Adjusting the maximum oil flow rate

Put the selector on the maximum operation. Adjust the oil pressure reading the value on the return manometer / pressure gauge according to the nozzle tables provided in the appendix.

NOTE: the pump pressure is set from the factory at the pressure required nozzle pressure required as per table of nozzle selection in appendix. If the output required is different from the one set from the factory the pressure can be adjusted according to the instruction below.

Servomotor SQM50 - Air damper motor pre-setting

The cams of the servomotor are set from the factory in order to start the burner and reach the maximum output.

The following setting are the standard one:

- I. High flame position 90° (maximum value 70°).
- II. Air flap position in standby 0° (minimum value 15°).
- III. Ignition position 30°.
- IV. Low flame position 40° (can be modified depending on the minimum output of the boiler).
- V. To VIII not used

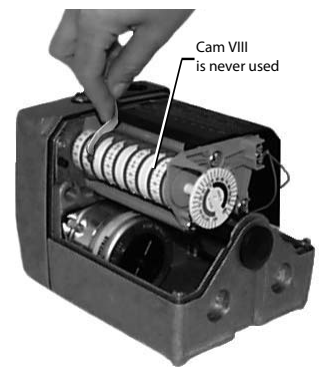

Adjusting the pump pressure

- 1 - INLET
- 2 - RETURN
- 3 - BLEED AND PRESSURE GAUGE PORT
- 4 - VACUUM GAUGE PORT
- 5 - PRESSURE ADJUSTMENT
- 6 - TO NOZZLE

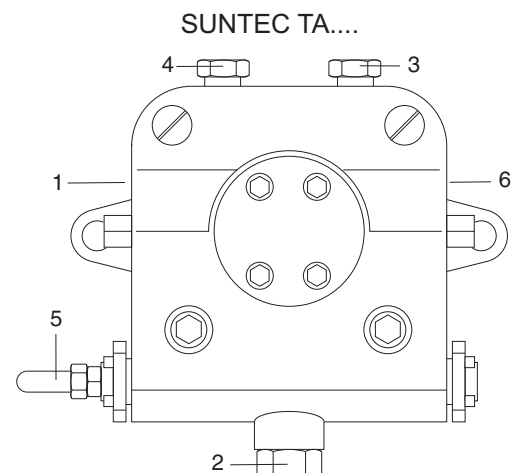

The pump pressure is set at a value of 22-25 bar during the testing of burners.

Before starting the burner, bleed the air in the pump through the gauge port.

Fill the piping with light oil to facilitate the pump priming. Start the burner and check the pump feeding pressure.

In case the pump priming does not take place during the first pre-purging, with a consequent, subsequent lock-out of the burner, rearm the burner's lock-out to restart, by pushing the button on the control box.

If, after a successful pump priming, the burner locks-out after the prepurging,

due to a fuel pressure drop in the pump, rearm the burner's lock-out to restart the burner.

Do never allow the pump working without oil for more than three minutes.



NOTE: before starting the burner, check that the return pipe is open. An eventual obstruction could damage the pump sealing device.

START-UP OIL SIDE

Adjusting the intermediate burner capacity

In order to adjust intermediate capacity of the burner use the selector on position 0 to stop the stroke and regulate the cam on the different screw position.

The adjustment shall be done according to the drawing in order to have the correct combustion value in each points "+/-" switch (different screw positions).

Using a suitable Allen wrench, change the position of the cam guide blade; if you screw it down, the flow rate is reduced; if you unscrew it, the flow rate increases.

WARNING: the variable profile of the cam shall have a normal proportional curvature in order to have good combustion values and reduce its mechanical stress breakdown.

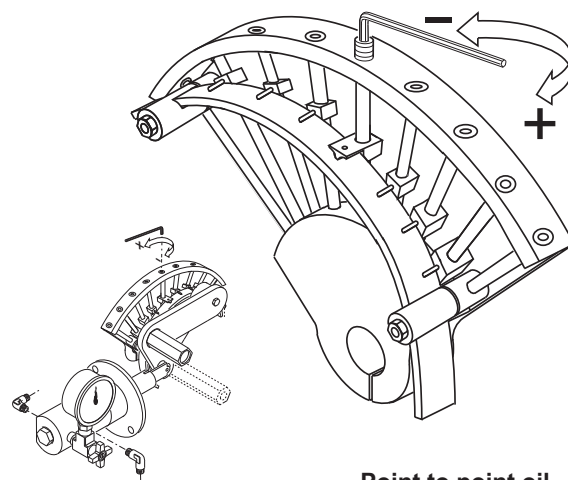
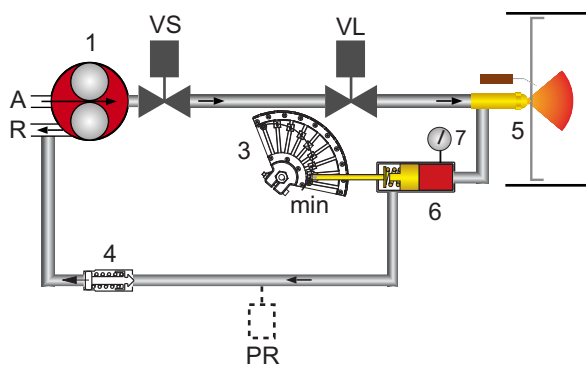
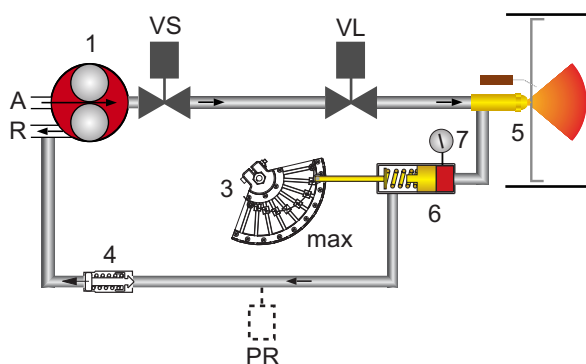

Point to point oil cam configuration



WARNING: Once the setting on the oil has been completed make sure that you close the manometer – pressure switch tap.

LEGENDA

1. Oil pump
- VS. Oil safety valve
3. Adjusting cam
4. Check valve
- VL. Working valve
- PR. Pressostat (optional)
5. Nozzle
6. Pressure regulator
7. Manometer – pressure gauge

Servomotor SQM50 - Oil side final setting

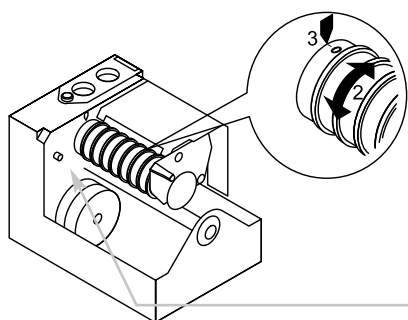

Once the point to point oil cam setting has been completed we need to set the final minimum output of the burner using the servomotor cam VI (low flame oil). Using the suitable key regulate the grades (" +/- " switch).

The low flame position must be higher than the ignition position cam on the servomotor. Turn the burner off and start it again in order to check if the burner start properly otherwise adjust the ignition oil cam number IV.

OIL SETTING ENDED: switch the selector to automatic position.



WARNING: Do not use the button cam drum release button.

MAINTENANCE PROGRAM



Burner and boiler servicing must only be carried out by authorised qualified personnel at least once a year. Depending on the type of installation, shorter maintenance intervals may be necessary. The system operator is advised to take out a maintenance contract to guarantee regular servicing.
WARNING: Use original spare parts.

SAFETY WARNINGS:

1. Turn off the power supply and protect the system from accidental start-up
2. Cut oil
3. Make sure there is no residual power in the system and that the actions in points 1 and 2 have been completed
4. Before opening the burner casing, ensure that the fan motor has stopped completely

Failure to observe any of these instructions will result in the risk of death or injury!

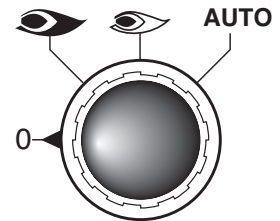

WORKS RECOMMENDED AS PART OF ANNUAL BURNER MAINTENANCE:

- Emergency stop button function check
- Check burner start characteristics
- Run burner test and input measurement in the boiler room
- Clean the combustion components and replace defective parts if necessary
- Check the combustion head components and make sure that all components are in good condition otherwise replace them
- Replace ignition electrodes and nozzle if necessary and check their correct position after any intervention
- Flame monitor and automatic combustion control unit function check
- Clean the fan wheel and the housing and grease rotating parts if necessary
- Clean the oil filter cartridge with gasoline periodically and check the tightening of the O rings, replace them if necessary
- Make visual inspection of the burner's electrical components and eliminate malfunctions if necessary
- Burner safety devices function check (air pressure/switches if any)
- Commissioning the burner and correct the adjustment values if necessary

NOTES ON REASSEMBLING: Perform the described step in reverse order and make sure to refit components as they were originally assembled and the system is free from leaks. Use only original spare parts.

DRAW UP A MEASUREMENT REPORT ACCORDING TO THE LOCAL REGULATION AND CODES OF PRACTISE OF THE COUNTRY

EXHAUST GAS LOSS

Exhaust gas loss by way of free heat will occur as a result of the temperature difference between the fuel-air mixture entering the furnace chamber and the gases discharged. Any increase in the excess of air and the resultant higher exhaust gas volume will cause the exhaust gas loss to rise. The exhaust gas loss can be calculated as follows:

$$q_A = (t_A - t_L) \frac{A_1}{CO_2} + B$$

- q_A = exhaust gas loss [%]
- t_A = exhaust gas temperature [°C]
- t_L = combustion air temperature [°C]
- CO_2 = volumetric content of carbon dioxide [%]

	Light oil EL	Heavy oil S	Natural gas	Town gas	LPG
A1	0,50	0,490	0,370	0,350	0,420
B	0,007	0,007	0,009	0,011	0,008

Example

Data measured in natural gas mode:
 CO₂ content of exhaust gases: 10,8%
 Exhaust gas temperature: 195°C
 Air intake temperature: 22°C

The exhaust gas loss can be calculated as follows:

$$q_{Af} = (195-22) \left(\frac{0,37}{10,8} + 0,009 \right) = 7,48\%$$

Data measured in fuel oil mode:
 CO₂ content of exhaust gases: 12,8%
 Exhaust gas temperature: 195°C
 Air intake temperature: 22°C

The exhaust gas loss can be calculated as follows:

$$q_{Af} = (195-22) \left(\frac{0,49}{12,8} + 0,007 \right) = 7,83\%$$

MAINTENANCE PROGRAM

REMOVING THE BLAST TUBE

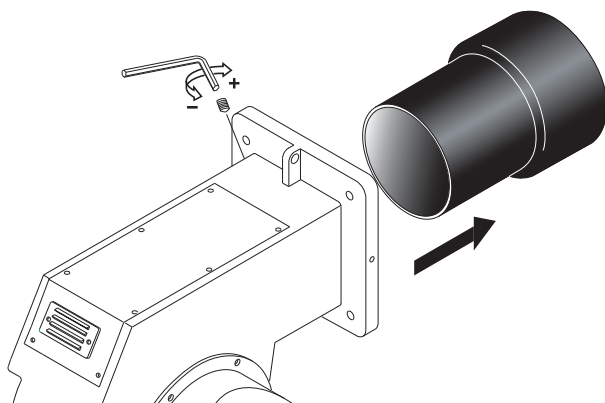

REMOVING THE FIRING HEAD

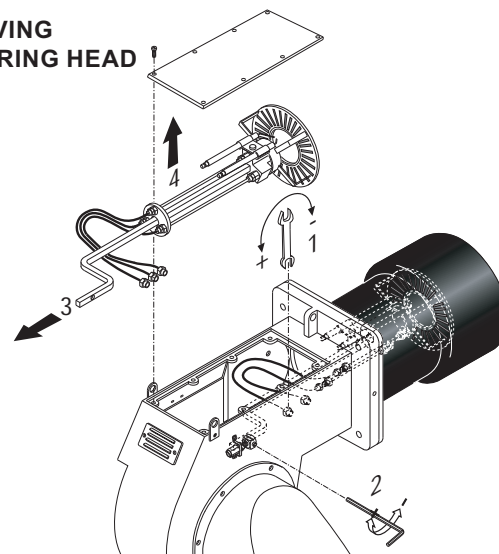

POSITION OF ELECTRODES

ATTENTION:

to remove the nozzle use the suitable box wrench taking care to not damage the electrodes. Check the position of the electrodes after any intervention as wrong position could cause ignition troubles.

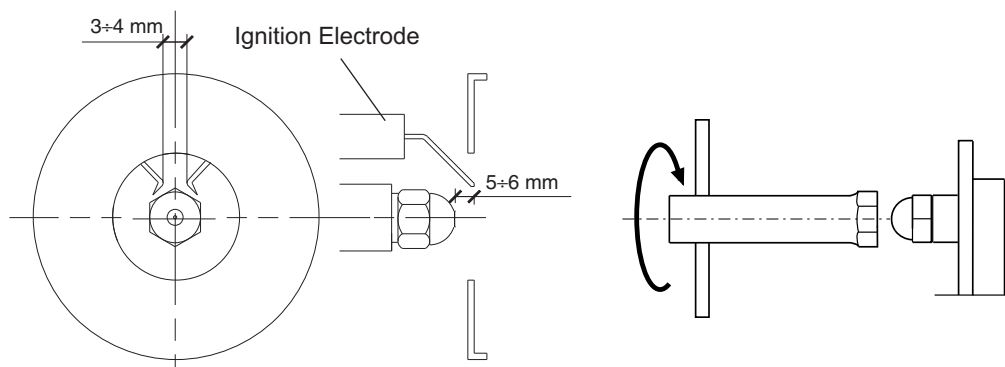

OIL FILTER CLEANING



ATTENTION: Periodically clean oil cartridge with gasoline and replace them if it is necessary!

TROUBLESHOOTING INSTRUCTIONS

The list of faults/causes/possible solutions for a set of main failures is a guideline for professional personell authorised to carry out service and maintenance.

Irregular burner operation or malfunction: check that every adjustment parameter is correctly set as per instruction on this manual.

TROUBLESHOOTING TABLE OIL OPERATION			Burner doesn't start	Fuel pump noisy / unprimes / leaks	Burner starts with continuous pre-purge	Burner starts and then goes into lock-out	Pilot Ignition failure (1st safety time - LFL only)	Main Ignition failure (2nd safety time)	Burner lock-out after flame appearance / pulsation	Flame control repeats the cycle and doesn't give consent	Smoke in flame - dark Bacharach	Burner doesn't switch into Hi flame	Burner lock-out during operation	LFL	LAL
STATUS	CAUSES	REMEDIES													
HEAVY OIL	Preheating period too long	Check GEFTRAN controller, replace if necessary	X								X		X	YES	YES
	Defective Gefran controller	Replace control unit	X								X		X	YES	YES
PRE-START (MISSING SIGNALS)	Defective control box unit	Replace control box unit	X			X	X	X	X	X		X	X	YES	YES
	No electrical power supply Wrong electrical connections	Check switches/contactors Check connections	X											YES	YES
	Air pressure switch not "closed"	Check contacts	X											YES	YES
	Boiler thermostats open	Check contacts	X											YES	YES
	Fan motor overload intervention	Replace fuse	X											YES	YES
	Auxiliaries fuses interrupted	Replace fuse	X											YES	YES
	Servomotor [CLOSE] position switch not reach	Check servomotor settings	X											YES	YES
PRE-START (OIL PUMP)	High vacuum in oil pipe due to dirty filter	Clean filter or replace filter cartridge		X							X			YES	YES
	Burner is higher than oil tank by more than 3 m	Reduce Height or prepare a ringline pump		X							X			YES	YES
	Air in the oil pipeline	Re-tighten pipe connections		X										YES	YES
SEQUENCE START	Servomotor [OPEN] position switch not reach	Check servomotor settings			X									YES	YES
	Servomotor [MIN] position switch not reach	Check servomotor settings			X									YES	YES
	Extraneous Light	Eliminate light source				X								YES	YES
	Fuel solenoid valve fails to close (Light oil Burner - direct ignition)	Clean valves or replace if necessary				X								YES	YES
LACK OF AIR	Air pressure switch fail to connect to Terminal 14	Check contacts				X								YES	NO
	Fan contaminated/dirty	Clean fan				X					X		X	YES	NO
	Fan motor rotation direction not correct	Check direction and contactor				X					X		X	YES	NO
IGNITION & FLAME STABILISATION PERIOD	Flame supervision circuit internal test failed	Replace control unit				X								YES	NO
	Pilot flame failure - Pilot gas valves not open	Check valves contacts / replace if necessary					X							YES	NO
	Pilot flame establish - weak flame signal	Check flame sensor Replace if necessary					X							YES	NO
	Ignition transformer faulty	Replace					X	X						YES	YES
	Ignition cable & electrodes defective	Replace					X	X						YES	YES
	Electrode bad position	Check setting / replace if necessary					X	X						YES	YES
	Fuel oil solenoid valve fails to open	Check contacts and clean valves. Replace solenoid coil if necessary						X						YES	YES
ONLY FOR OIL BURNER	Air pressure switch not close, Oil pump contactor open	Check air pressure switch contacts						X						NO	YES
	No oil supply	Check shut-off valves Check Pump, replace if necessary						X						NO	YES
	Oil pump coupling broken	Replace pump unit						X						NO	YES
COMBUSTION	Flame sensor signal failure	Clean, re-position or replace if necessary				X	X	X	X				X	YES	YES
	Head adjustment not correct	Check settings							X		X		X	YES	YES
	Oil/Air mixture setting not correct	Check settings							X		X		X	YES	YES
	Dirty combustion head	Clean or replace disk if necessary							X		X		X	YES	YES
	Nozzle dirty or damaged	Clean or replace nozzle if necessary							X		X			YES	YES
	Fuel pressure inappropriate	Adjust pressure or replace pump if necessary							X		X		X	YES	YES
	Capacity reduction	Check filter, pump pressure and nozzle. Replace item if necessary									X			YES	YES
	Load control device does not close	Check load control, replace if necessary										X	X	YES	YES

OPERATING TROUBLE

In case of operating trouble it should be checked whether the system is in proper working order.

Make a check for the following:

1. Availability of fuel.
Correct position of fuel selector switch.
2. Availability of electric power in the burner system.
3. Proper functional order and setting of all control and safety instruments such as temperature controller, safety limiter, water failure cut-out, electrical limit switches, etc.

If the trouble is not found to be due to any of the above-mentioned points it will be necessary to test the burner functions very carefully.

Prevailing conditions:

The burner will be found to be out of operation and in faulty and interlocked position. Proceed with searching for the cause of the trouble and eliminate it. Unlock the control box by pressing the fault eliminate key and start the burner.

Do not press the fault eliminate key longer than 10 seconds.

The start-up program will be initiated and should be carefully monitored.

The possible cause of the fault may be quickly found by reference to the fault indicator of the control box and watching the start-up and operating program.

Control program in the case of trouble and fault indicator LAL 1... / LAL 2...

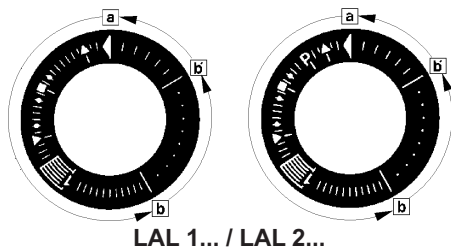

LAL 1... / LAL 2...

a-b Starting program

b-b' In a number of time versions; idle steps of the program unit to self-stop after burner start-up (b' = operating position of program unit)

b(b')-a After-flushing program after regular stop. In the starting position "a" the program unit will automatically stop or initiate an immediate restart of the burner, e.g. after a fault has been eliminated

- Duration of the safety period for single-tube burners
- Duration of the safety period for burners with ignition gas valve

Basically, any type of trouble will result in the immediate stop of the fuel supply. At the same time, the program unit and consequently the fault indicator will stop. The type of trouble can be identified by the symbol opposite to the reading mark of the indicator:

◀ **No start**, e.g. because the "CLOSED" signal from the "Air Damper CLOSED" limit switch is missing or a contact is not closed between terminals (12) and (4) or (4) and (5); or the contacts of all control and safety units in the controlled system are not closed (e.g. gas pressure or air pressure switches, temperature or pressure regulators).

▲ **Operating stop** because the "OPEN" signal from the "Air Damper OPEN" limit switch is missing. Check and adjust the limit switch concerned.

P **Shut-off on trouble because there is not air pressure** signal at the beginning of the air pressure check (apply only to LAL 2.25).

Any air pressure failure after this time will also lead to a shut-off on trouble.

■ **Shut-off on trouble** because of a fault in the flame monitoring circuit.

▼ **Operating stop** because the position signal of the "Partial Load" limit switch (air damper in "Partial Load" position) is not available on terminal (8). Check and adjust the limit switch concerned.

1 **Shut-off on trouble** because a flame signal is not available on the expiry of the (1st) safety time.

Any failure of the flame signal on the expiry of the safety time will also lead to a shut-off on trouble.

| **Shut-off on trouble** because the flame signal failed during burner operation or a lack of air has occurred.

◀ **Shut-off on trouble** during or after the control program flow due to external light (e.g. by flame not extinguished, leaking fuel valves) or a faulty flame signal (e.g. fault in flame monitoring circuit, or similar); see flame monitor.

If the shut-off on trouble occurs at any other time between start and pre-ignition that is not identified by a symbol as above, this will normally be due to an early flame signal which is considered to be a faulty flame signal.

The automatic furnace controller may be unlocked immediately after a shut-off on trouble using the unlock button with integrated fault signal lamp or an external switch. After it has been unlocked (and after a defect with resultant operating stop has been eliminated and after a voltage failure), the program unit will in any case return to its starting position with voltage being only supplied to terminals 7, 9, 10 and 11 as preset by the control program. It is only at this stage that the program of the automatic furnace controller will restart the burner.

APPENDIX

Control box - Damper actuators

CONTROL BOX LAL...

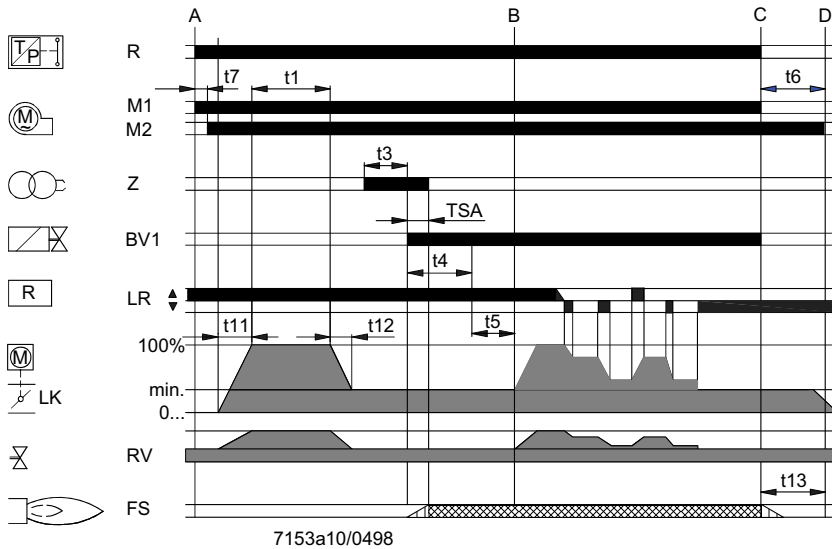

A: Starting type interval
 A-B: Flame development interval
 B: Burner has reached operating position
 B-C: Burner operation (heat generation)
 C-D: Regular shut-off
 t1: Pre-ventilating time
 t2: Safety time
 t3: Pre-ignition time
 t4: Fuel valve enable
 t5: Load regulator enable
 t11: "OPEN" run time of air damper
 t12: "CLOSE" run time of air damper

BV: Fuel valve
 FS: Flame signal amplifier
 LK: Air damper
 LR: Load controller
 M: Fan or burner motor
 R: Control thermostat or pressurestat
 RV: Modulating fuel valve
 Z: Ignition transformer

DAMPER ACTUATORS SQM50...

Description

The SQM actuator is intended for use with two-stage sliding or modulating oil, gas or dual-fuel burners. The reversible actuator is fitted with a synchronous motor which drives a shaft via a gearbox. The shaft end carries a coupling to drive the fuel and combustion air controlling element.

The SQM actuator has been designed for dual-wire control by controller or switching units with change-over contacts.

Potentiometers can be installed for a range of applications on customer's request.

The limit and auxiliary switches are set by means of manually adjustable latching cam plates. Scales are fitted between the disks to facilitate the selection of the switching points.

The cam plates are provided with a small pointer for indicating the switching point of a scale between the setting ranges.

An additional scale fitted to the end of the cam roller serves to indicate the position of the actuator.

The drive unit may be disconnected from the controlling element by changing over a rocker arm mounted to the gearbox.

This will allow any desired position of the controller plate to be selected by hand. Drive and output will be coupled in the vertical position of the rocker arm.

The fuel-air curve should be set over the full range of the cam plate so that operating safety will be retained also when the limit switch is overrun.

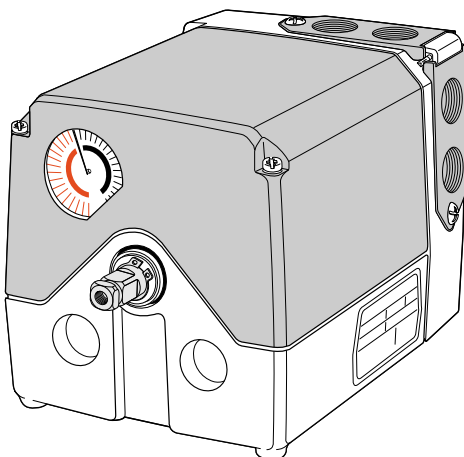

APPENDIX

Fluidics nozzle chart

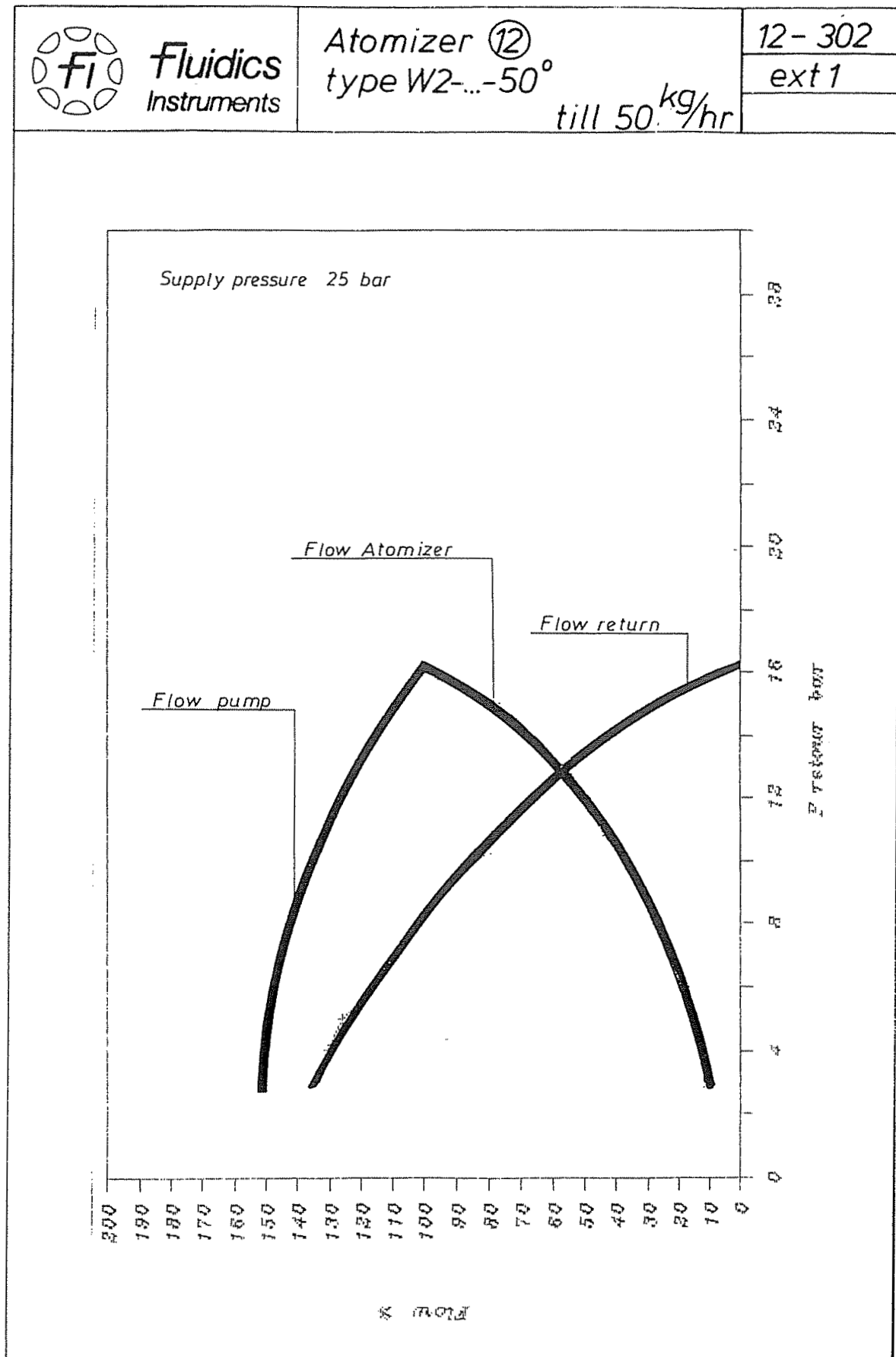

APPENDIX

Fluidics nozzle chart

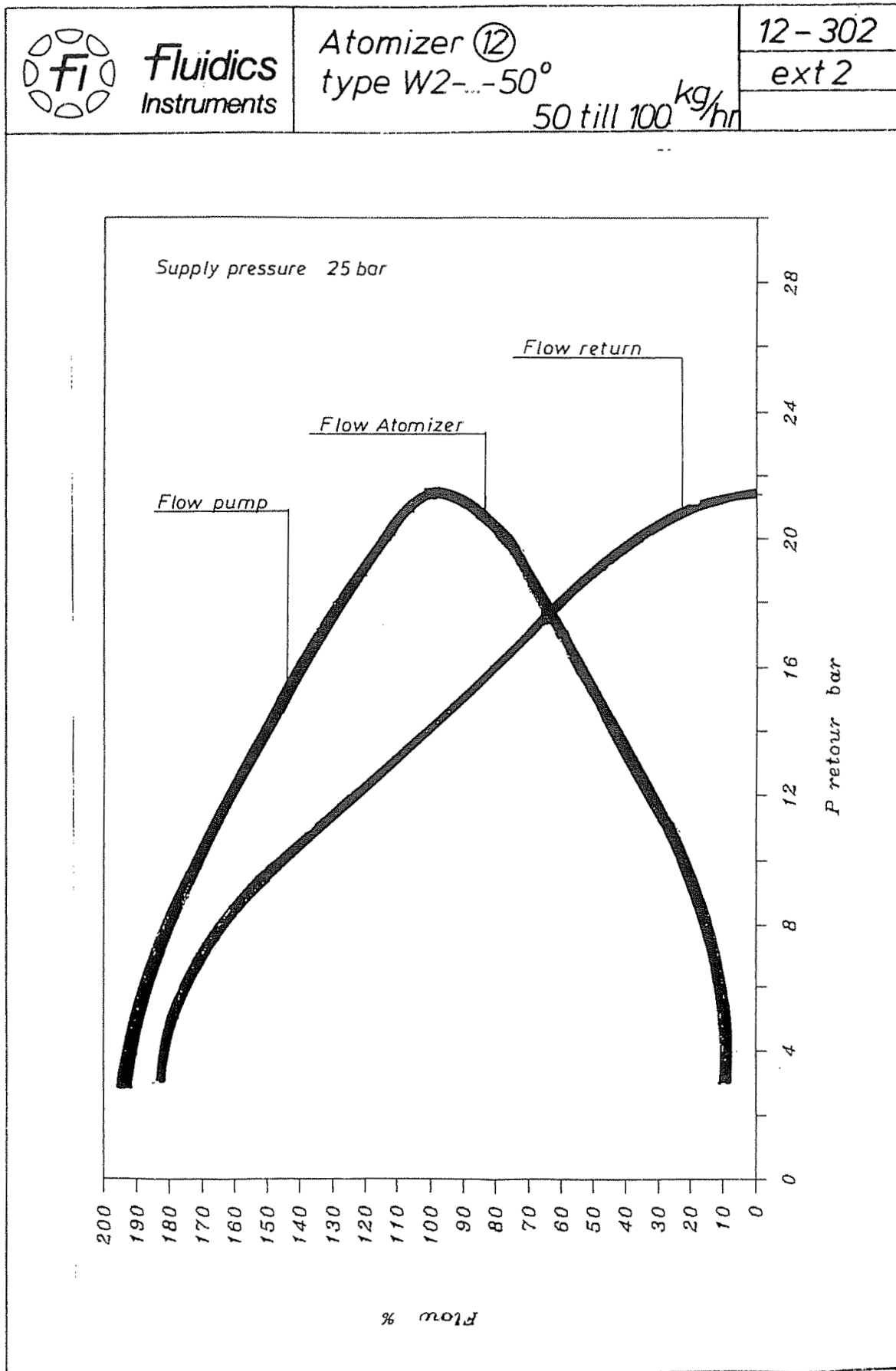

APPENDIX

Fluidics nozzle chart

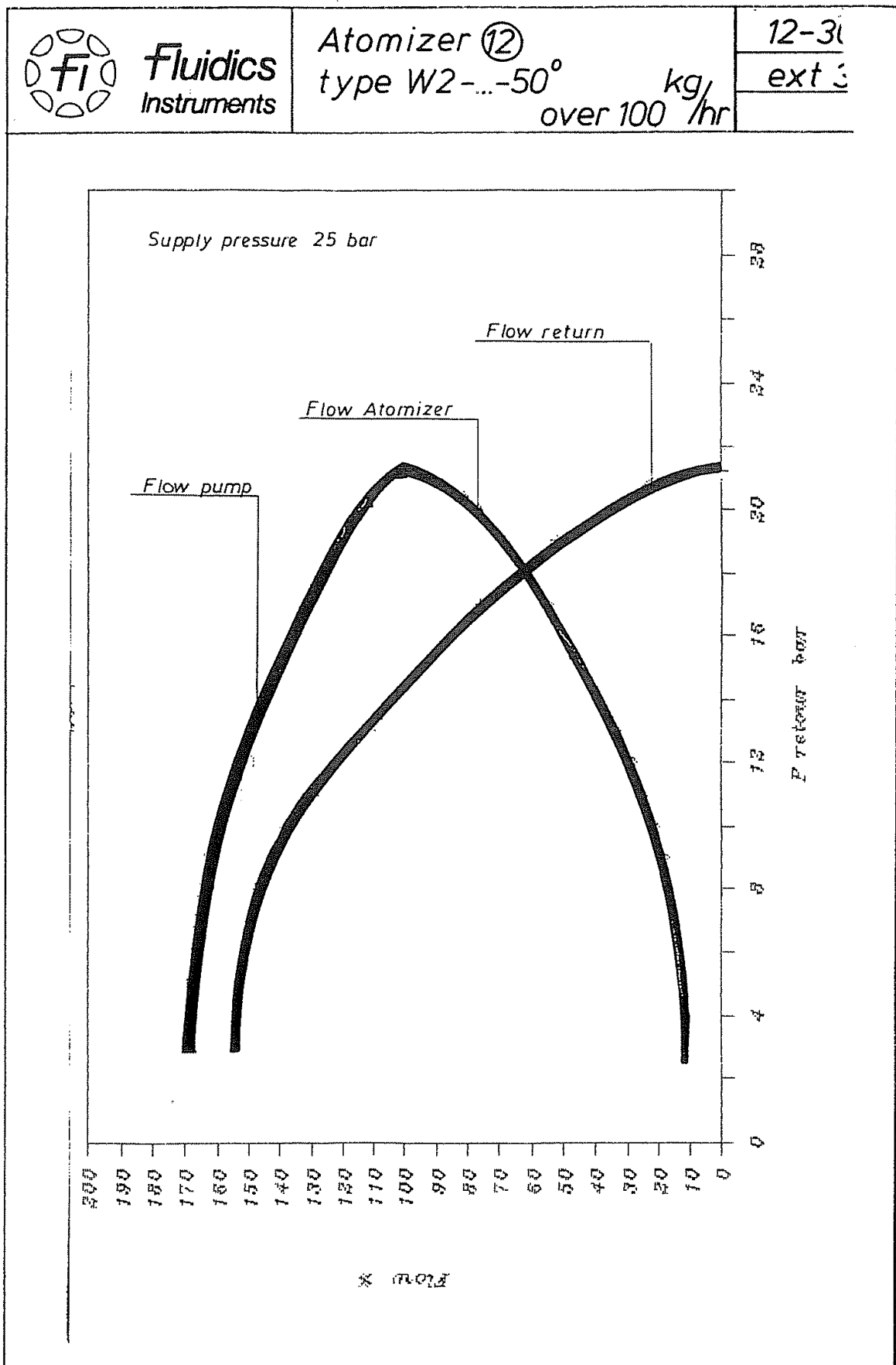

APPENDIX

Bergonzo nozzle tables

Return pressure [bar]

Nozzle kg/h	Bar	3	4	5	6	7	8	9	10	11	12	13	14	15	16	17	18	19	20	21	22	23	24	25	26	27	28	29	
100	A	20	28	29	29	30	31	32	34	36	38	40	45	48	52	60	70	90											
100	B	20	250	250	250	248	245	240	235	220	200	190	180	170	155	135	115	90											
100	A	25	32	33	33	34	34	35	36	37	38	40	42	43	45	47	49	52	58	62	72	90							
100	B	25	290	290	280	275	273	270	268	265	248	240	225	215	200	190	180	170	160	140	125	110							
100	A	30	33	33	33	33	34	34	34	35	36	37	38	41	44	46	48	50	52	54	59	64	69	75	80	90	100		
100	B	30	310	310	308	306	304	302	300	295	290	285	280	275	265	255	245	235	225	210	200	190	180	170	150	140	120		
125	A	20	38	39	40	41	42	43	44	45	49	53	61	65	69	73	95	100											
125	B	20	300	300	295	285	275	275	265	245	230	215	200	185	174	153	140	120											
125	A	25	41	42	43	44	45	46	47	48	49	51	53	55	58	60	64	68	72	80	88	105	120						
125	B	25	330	330	330	325	320	315	310	305	295	290	285	280	265	240	230	220	200	190	170	150	130						
125	A	30	43	43	43	44	44	45	45	46	47	48	50	52	54	54	58	62	64	67	70	75	78	81	90	98	110	130	
125	B	30	360	359	358	357	356	355	355	345	345	340	335	330	320	310	300	290	280	270	255	240	220	205	190	175	155	135	
150	A	20	47	48	50	52	54	56	58	61	64	68	72	78	85	92	100	110											
150	B	20	280	279	278	277	276	275	268	260	240	230	215	190	175	160	145	125											
150	A	25	52	52	53	54	55	56	57	58	60	64	68	72	76	80	85	90	97	105	118	128	142						
150	B	25	325	325	310	300	290	285	280	275	270	265	260	255	250	240	230	220	210	190	170	160							
150	A	30	57	56	55	54	54	55	57	58	59	60	62	65	68	72	75	80	84	88	93	99	105	112	120	130	145	145	
150	B	30	340	340	340	338	336	334	332	330	328	324	320	315	310	300	290	280	270	260	250	240	230	220	210	190	180	160	
175	A	20	55	57	59	62	64	66	68	72	75	80	82	90	95	102	115	130	150										
175	B	20	285	280	275	270	270	265	265	260	255	245	240	230	200	185	170	150											
175	A	25	60	61	62	63	64	65	66	68	70	72	78	80	82	85	92	98	105	110	120	140	160						
175	B	25	330	330	330	330	325	325	325	320	315	300	295	280	270	260	252	245	235	225	200	180							
175	A	30	67	68	69	70	71	72	73	74	75	76	77	79	80	82	85	90	92	95	100	105	110	118	125	140	160	180	
175	B	30	360	360	360	355	355	350	345	345	340	340	335	330	330	325	320	310	300	290	280	270	260	250	240	225	200		
200	A	20	57	58	59	60	62	65	68	72	78	82	92	100	110	125	140	160	180										
200	B	20	350	350	350	345	345	340	330	325	300	285	275	260	245	220	200	190											
200	A	25	65	66	67	68	70	71	73	75	78	81	86	90	95	100	108	115	122	135	150	170	190						
200	B	25	400	400	400	400	390	385	380	375	370	365	360	350	340	330	320	300	285	270	260	245	220						
200	A	30	66	67	68	68	69	70	71	72	75	78	80	82	88	92	98	102	108	113	118	125	130	140	155	175	225		
200	B	30	460	460	460	460	458	456	452	448	440	430	420	405	390	380	370	360	350	342	335	325	315	300	290	275	260	245	
225	A	20	65	68	70	72	76	79	84	88	91	94	102	110	118	125	140	160	200										
225	B	20	420	410	405	400	390	382	376	370	350	345	335	320	300	280	265	250											
225	A	25	72	73	74	75	75	76	79	82	85	88	91	95	100	105	115	120	130	145	160	180	225						
225	B	25	475	468	460	460	460	455	455	450	440	430	420	410	400	380	365	345	325	315	300	275	260						
225	A	30	78	78	78	79	79	80	82	84	86	88	90	91	94	98	100	110	115	118	125	130	135	145	155	175	200	240	
225	B	30	510	510	505	505	503	500	495	490	485	480	475	470	465	455	445	435	425	410	392	380	370	360	350	325	300	275	
250	A	20	76	78	80	84	88	90	94	105	110	118	125	135	145	160	180	220											
250	B	20	425	415	408	403	400	380	375	365	355	345	330	315	300	285	275	250											
250	A	25	87	88	88	89	91	94	96	100	104	108	112	122	132	142	155	162	175	180	210	225	250						
250	B	25	480	475	475	470	465	465	460	455	445	435	425	415	405	382	365	350	345	330	320	300	280						
250	A	30	89	90	90	92	94	95	96	98	102	106	109	112	118	124	136	144	155	160	170	180	190	210	225	235	265		
250	B	30	520	518	518	515	512	512	510	510	508	504	500	490	480	470	460	450	440	430	420	410	390	375	360	340	320	300	

A = nozzle output B = pump output

Output [kg/h]

Supply: 25 bar

APPENDIX

Bergonzo nozzle tables

Return pressure [bar]

Nozzle kg/h	Bar	3	4	5	6	7	8	9	10	11	12	13	14	15	16	17	18	19	20	21	22	23	24	25	26	27	28	29			
275	A	20	80	84	88	92	96	98	104	112	118	125	135	142	152	170	190	230													
275	B	20	475	475	470	466	460	445	430	420	405	390	370	360	350	330	310	285													
275	A	25	92	93	94	95	96	98	100	105	110	118	120	130	138	145	155	164	178	195	210	240	265								
275	B	25	525	525	525	520	515	510	505	500	495	490	480	470	460	450	440	425	400	375	350	325	300								
275	A	30	105	106	107	108	109	110	112	116	118	120	125	130	135	138	142	148	154	160	170	180	190	210	225	250	280				
275	B	30	600	600	600	600	600	600	595	590	585	580	570	565	543	530	515	500	490	475	465	450	440	425	400	380	360	330			
300	A	20	85	88	90	94	98	100	105	110	115	125	135	145	155	170	190	225	275												
300	B	20	480	480	480	476	470	465	460	450	435	415	400	375	365	350	325	300	280												
300	A	25	100	100	100	102	104	106	108	110	113	116	120	125	135	145	155	165	180	200	225	255	310								
300	B	25	550	550	545	540	535	530	520	510	500	490	482	475	463	450	440	430	415	390	370	350	310								
300	A	30	105	106	107	108	110	112	114	116	118	120	124	128	132	136	140	146	152	162	175	182	195	210	230	260	290	340			
300	B	30	625	625	625	620	615	610	605	600	590	580	570	560	550	540	530	520	510	495	480	465	450	430	410	390	375	350			
325	A	20	95	96	97	98	100	103	106	110	120	130	140	150	165	200	240	260													
325	B	20	550	545	540	535	530	520	510	500	480	460	440	420	400	375	355	325													
325	A	25	108	107	108	109	110	112	114	116	118	125	132	141	150	160	170	180	200	225	250	280	330								
325	B	25	630	630	630	625	620	615	610	605	600	585	570	565	535	520	500	480	460	440	410	385	360								
325	A	30	115	115	116	117	118	119	120	122	126	130	135	140	147	152	160	170	180	190	200	210	225	242	260	280	310	330			
325	B	30	720	715	710	705	702	700	700	690	680	670	655	620	610	600	580	570	550	520	500	480	460	440	420	400	380				
350	A	20	105	107	108	109	110	115	118	125	135	145	155	170	190	215	240	275													
350	B	20	590	580	570	560	550	540	530	500	480	465	450	440	400	375	360	340													
350	A	25	120	122	124	126	128	132	134	136	138	140	145	150	155	165	175	185	200	225	255	275	350								
350	B	25	620	620	620	615	614	612	610	605	600	595	575	565	550	530	510	490	470	450	410	380	360								
350	A	30	125	125	127	129	131	133	135	138	141	143	145	150	155	160	168	174	184	195	210	225	245	265	280	325	370				
350	B	30	710	710	708	704	703	702	700	690	680	670	660	650	640	630	615	600	580	560	540	520	500	475	440	425	400				
375	A	20	110	114	118	127	134	137	140	145	152	162	170	180	195	210	250	290													
375	B	20	600	590	580	575	560	550	540	530	515	500	485	465	450	425	400	370													
375	A	25	130	130	130	132	134	136	138	140	146	150	155	160	170	180	195	210	230	250	275	320	375								
375	B	25	690	690	680	680	670	660	650	630	620	610	600	580	560	540	520	500	485	465	450	425	400								
375	A	30	135	136	137	138	139	140	142	144	148	151	155	160	166	172	180	190	200	210	225	235	250	270	300	340	370				
375	B	30	790	780	770	760	750	740	730	720	710	700	690	682	674	666	658	650	632	615	600	575	545	530	525	480					
400	A	20	130	135	140	145	150	155	160	170	180	190	205	220	240	263	330	370													
400	B	20	650	650	650	640	630	620	610	600	580	560	540	500	475	420	420	380													
400	A	25	130	135	140	145	150	155	160	170	178	185	195	202	212	225	250	270	290	320	340	375	400								
400	B	25	725	725	720	720	715	710	705	700	690	670	640	630	600	580	565	550	525	480	470	450	425								
400	A	30	152	153	154	155	157	162	165	170	176	180	190	200	210	220	230	245	260	270	285	300	325	365	400	425	450				
400	B	30	845	840	835	830	825	820	815	810	805	800	790	780	760	740	715	690	660	650	620	600	580	560	540	520	500				
425	A	20	120	125	130	135	140	145	150	165	175	185	210	230	250	275	300	350													
425	B	20	700	690	680	670	660	650	635	615	600	575	550	525	505	465	435	400													
425	A	25	145	146	147	148	149	150	154	157	160	170	180	190	210	225	245	265	280	320	360	400									
425	B	25	800	800	800	790	780	770	760	750	725	700	685	670	650	625	600	575	550	510	480	450									
425	A	30	150	150	149	148	147	146	145	148	154	160	168	177	185	195	205	225	238	250	270	290	310	325	360	380	450				
425	B	30	880	875	870	865	860	855	850	840	830	820	810	800	780	760	740	720	700	685	670	650	610	590	570	550	510				

Supply: 25 bar

A = nozzle output

B = pump output

Output [kg/h]

APPENDIX

Pumps and pressure regulators

PUMP SUNTEC TA TECHNICAL DATA

Note: All TA models are delivered for two-pipe system (by-pass plug fitted in vacuum gauge port).
For one-pipe system, the by-pass plug must be removed and the return port sealed by steel plug and washer.

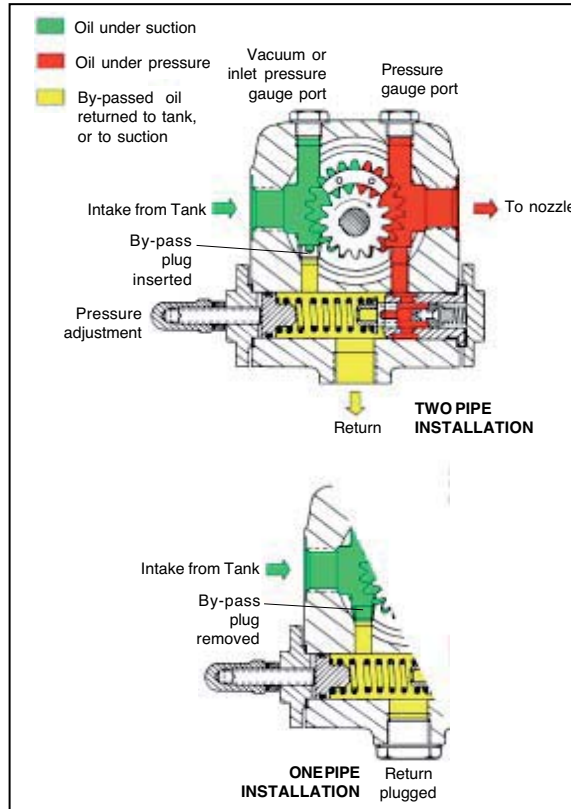
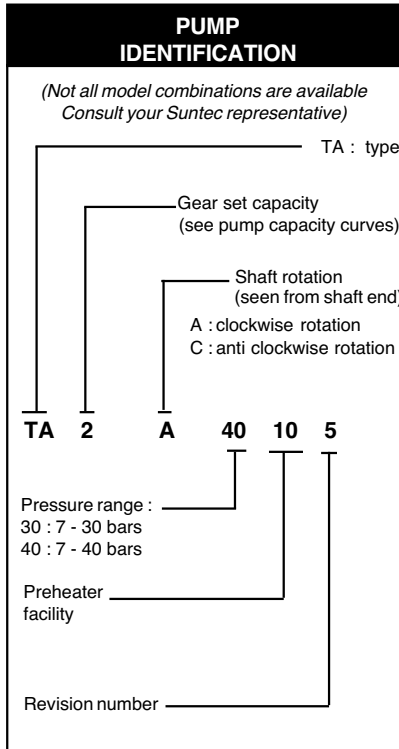

General

Mounting	Flange mounting	
Connection threads	Cylindrical according to ISO 228/1	
Inlet end return	G 1/2"	
To nozzle	G 1/2"	
Pressure gauge port	G 1/4"	
Vacuum gauge port	G 1/4"	
Shaft	Ø 12 mm	
By-pass plug	Inserted in vacuum gauge port for 2 pipe system; to be removed with a 3/16" Allen key for 1 pipe system	
Weight	5,4 kg (TA2)	5,7 kg (TA3)
	6 kg (TA4)	6,4 kg (TA5)

Hydraulic data

Nozzle pressure ranges	30 : 7 - 30 bars 40 : 7 - 40 bars
Delivery pressure setting	30 bars
Operating viscosity	4 - 450 cSt
Oil temperature	0 - 140°C max. in the pump
Inlet pressure	light oil : 0,45 bars max. vacuum to prevent air separation from oil heavy oil : 5 bars max.
Return pressure	light oil : 5 bars max. heavy oil : 5 bars max.
Rated speed	3600 rpm max.
Starting torque	0,3 N.m

Choice of heater

Cartridge	Ø 12 mm
Fitting	according to DIN 40430, NFC 68190 (N°9 elec.)
Rating	80-100 W

Pump capacity

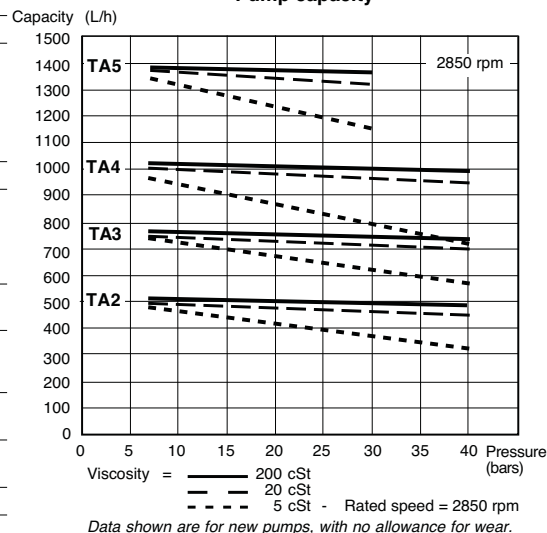

APPENDIX

Electrical diagrams

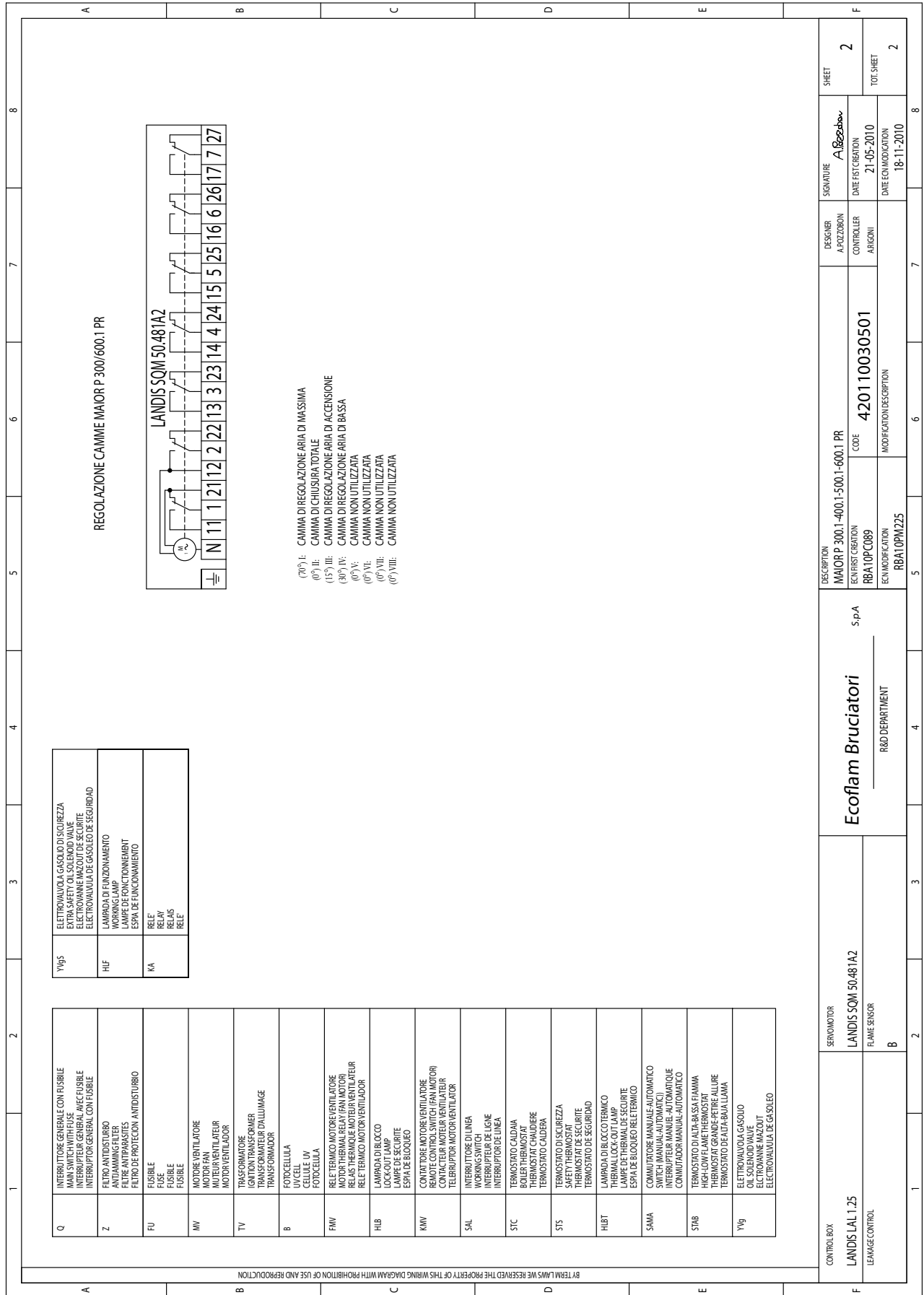

APPENDIX

Spare parts

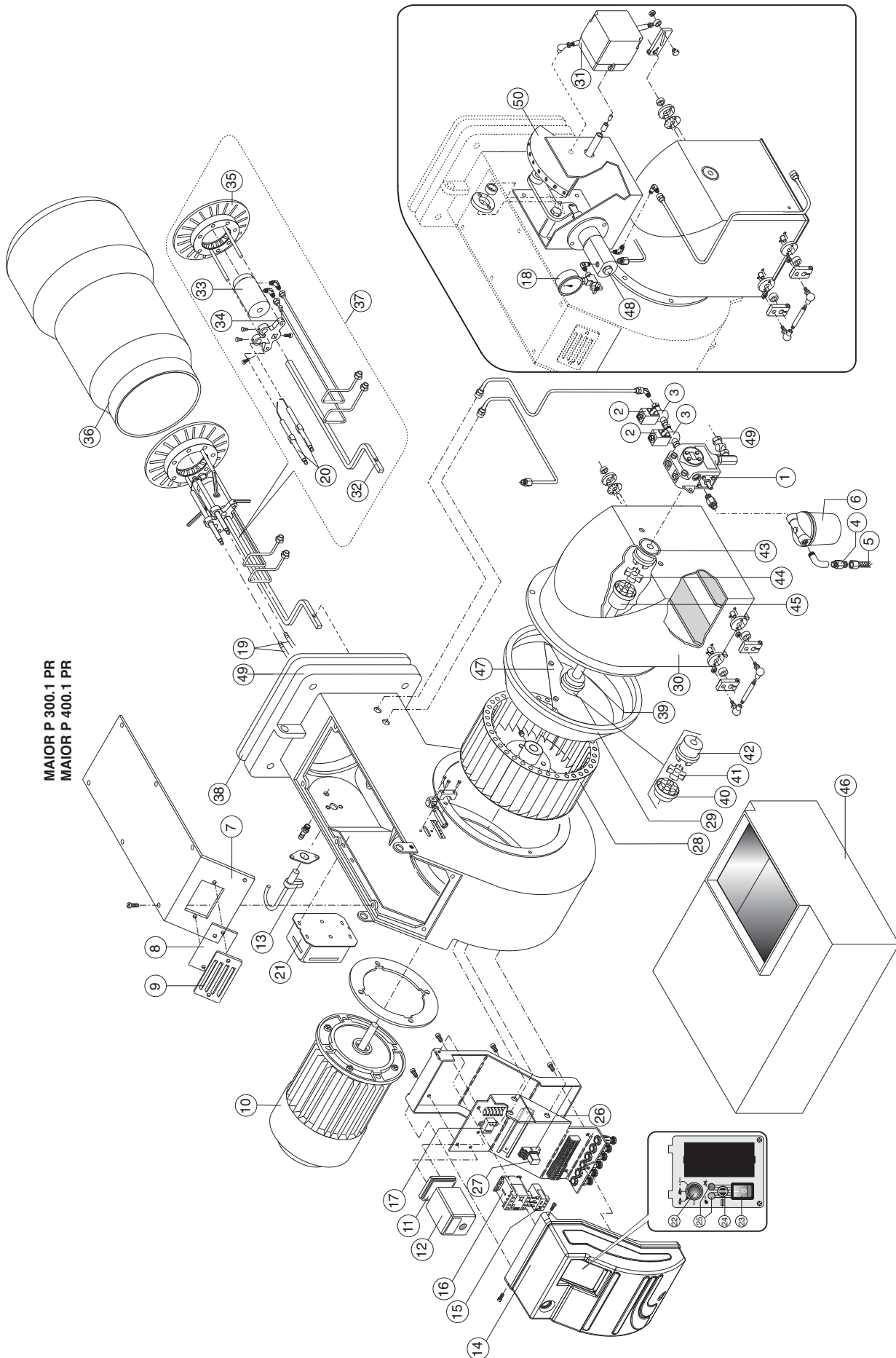

APPENDIX

Spare parts list

N°	DESCRIPTION		MAIOR P 300.1 PR	MAIOR P 400.1 PR
			code	code
1	OIL PUMP	SUNTEC TA3C40105	65322992	65322992
2	COIL	LUCIFER 1/2 E321H25	65323810	65323810
3	OIL VALVE	LUCIFER 1/2 E321H25	65323633	65323633
4	NIPPLE	TN 18X1200	65323183	65323183
5	HOSES	TN 18X1500	65323182	65323182
6	FILTER	70501/03	65324103	65324103
7	COVER		65320678	65320678
8	GLASS		65320487	65320487
9	PEEP WINDOW FRAME		65320488	65320488
10	MOTOR	7,5 kW	65326331	-
		9 kW	-	65326332
11	CONTROL BOX BASE	SIEMENS	65320091	65320091
12	CONTROL BOX	SIEMENS LAL1.25	65320052	65320052
13	PHOTORESISTOR	SIEMENS	65320076	65320076
14	COVER		65320473	65320473
15	MOTOR THERMAL RELAY	AEG 14,5-18A	65323120	-
		AEG 21-26A	-	65324066
16	REMOTE CONTROL SWITCH	AEG LS15K.00	65323136	65323136
17	ANTI JAMMING FILTER		65323170	65323170
18	MANOMETER	CEWAL R1/4 D50-40 BAR	65324105	65324105
19	CABLE	TC	65320947	65320947
		TL	65320948	65320948
20	ELECTRODES		65325903	65325903
21	IGNITION TRANSFORMER	Brahma T8 13000/35	65323222	65323222
22	SELECTOR		65323067	65323067
23	MAIN SELECTOR	cod.4010011509	65323064	65323064
24	FUSE SUPPORT	FUSIT FH-B 528	65322181	65322181
25	LAMP	EL/N-SC4 Elettrospring	65322053	65322053
26	RELAY BASE	FINDER 5532	65323149	65323149
27	RELAY	FINDER 5532	65323139	65323139
28	FAN	320 x 150	65321800	65321800
29	AIR CONVEYOR		65320645	65320645
30	COVER AIR INLET		65320560	65320560
31	AIR DAMPER MOTOR	SQM50.481A2	65322902	65322902
32	ROD	TC	65324807	65324807
		TL	65320246	65320246
33	NOZZLE HOLDER		65320716	65320716
34	DIFFUSER SUPPORT		65324515	65325053
35	DIFFUSER		65320785	65320784
36	BLAST TUBE	TC	65324808	65325041
		TL	65320455	65320456
37	INNER ASSEMBLY	TC	65325576	65325578
		TL	65325577	65325579
38	GASKET		65321125	65321125
39	ROD		65321463	65321463
40	COUPLING (FAN)		65321789	65321789
41	UNION (FAN)		65321791	65321791
42	COUPLING		65321790	65321790
43	COUPLING (PUMP)		65074169	65074169
44	UNION (PUMP)		65321786	65321786
45	COUPLING		65321782	65321782
46	SILENCER		65324107	65324107
47	FLAP		-	65320627
48	ADJUSTMENT PRESSURE		65322350	65324304
49	CHECK VALVE	ART. FZVR1	65325066	65325066
50	OIL CAM GROUP		65322356	65322356

TC = SHORT HEAD TL = LONG HEAD

Ecoflam

Ecoflam Bruciatori S.p.A.

Via Roma, 64 - 31023 Resana (TV) - Italy

Tel. +39 0423 719500

Fax +39 0423 719580

<http://www.ecoflam-burners.com>

e-mail: export@ecoflam-burners.com

Società soggetta alla direzione e al coordinamento di Ariston Thermo S.p.A.

Via A. Merloni, 45 - 60044 Fabriano (AN) - CF 01026940427

Ecoflam Bruciatori S.p.A. reserves the right to make any adjustments, without prior notice, which is considered necessary or useful to its products, without affecting their main features

Ecoflam Bruciatori S.p.A. si riserva il diritto di apportare ai prodotti le modifiche che riterrà necessarie o utili, senza pregiudicarne le caratteristiche principali.

La maison Ecoflam Bruciatori S.p.A. se réserve le droit d'apporter les modifications qu'elle jugera nécessaires ou utiles à ses produits sans pour autant nuire à leurs caractéristiques principales

Ecoflam Bruciatori S.p.A. se reserva el derecho a introducir en sus productos todas las modificaciones que considere necesarias o utiles, sin perjudicar sus características

"Ecoflam Bruciatori S.p.A." оставляет за собой право вносить в конструкцию оборудования любые необходимые изменения без особого предупреждения